

# Module 3

## INTERFEROMETER AND SCREW THREAD, GEAR MEASUREMENT

### CONTENTS

3.1 Interferometer

3.2 Autocollimator

3.3 Optical flats

3.5 Terminology of screw threads

3.6 Measurement of major diameter, minor diameter, pitch, angle and effective diameter of screw threads by 2-wire and 3-wire methods, best size wire.

3.7 Tool maker's microscope,

3.8 Gear tooth terminology, uses of gear tooth verniercaliper and micrometer.

### OBJECTIVES

After studying this unit, you should be able to

1. familiarize yourself with the principle of interference, and
2. Understand the techniques and working of various devices based on the phenomenon of interference.

## 4.1 Interferometers:

They are optical instruments used for measuring flatness and determining the length of the slip gauges by direct reference to the wavelength of light. It overcomes the drawbacks of optical flats used in ordinary daylight. In these instruments the lay of the optical flat can be controlled and fringes can be oriented as per the requirement. An arrangement is made to view the fringes directly from the top and avoid any distortion due to incorrect viewing.

## 4.2 Autocollimators

This is an optical instrument used for the measurement of small angular differences. For small angular measurements, autocollimator provides a very sensitive and accurate approach. Auto-collimator is essentially an infinity telescope and a collimator combined into one instrument. The principle on which this instrument works is given below. O is a point source of light placed at the principal focus of a collimating lens in Fig. 8.30. The rays of light from O incident on the lens will now travel as a parallel beam of light. If this beam now strikes a plane reflector which is normal to the optical axis, it will be reflected back along its own path and refocused at the same point O. If the plane reflector be now tilted through a

small angle  $\theta$ , [Refer Fig] then parallel beam will be deflected through twice this angle, and will be brought to focus at  $O'$  in the same plane at a distance  $x$  from O. Obviously  $OO' = x = 2\theta.f$ , where  $f$  is the focal length of the lens.

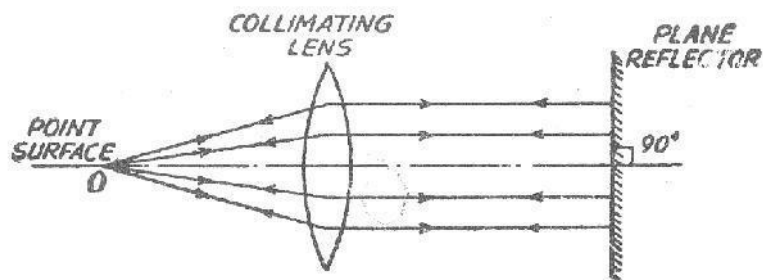

There are certain important points to appreciate here :

The position of the final image does not depend upon the distance of reflector from the lens, i.e. separation  $x$  is independent of the position of reflector from the lens. But if reflector is moved too much back then reflected rays will completely miss the lens and no image will be formed. Thus for full range of readings of instrument to be used, the maximum remoteness of the reflector is limited.

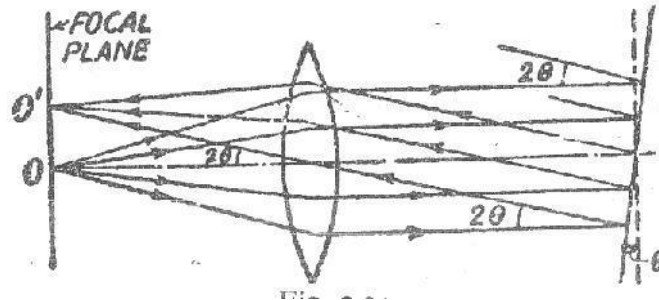

For high sensitivity, i.e., for large value of  $x$  for a small angular deviation  $\theta$ , a long focal length is required.

**1. Principle of the Autocollimator.** A crossline “target” graticule is positioned at the focal plane of a telescope objective system with the intersection of the crossline on the optical axis, i.e. at the principal focus. When the target graticule is illuminated, rays of light diverging from the intersection point reach the objective via a beam splitter and are projected from the objective as parallel pencils of light. In this mode, the optical system is operating as a

“collimator”

A flat reflector placed in front of the objective and exactly normal to the optical axis reflects the parallel pencils of light back along their original paths. They are then brought to focus in the plane of the target graticule and exactor coincident with its intersection. A proportion of the returned light passes straight through the beam splitter and the return image of the target crossline is therefore visible through the eyepiece. In this mode, the optical system is operating as a telescope focused at infinity.

If the reflector is tilted through a small angle the reflected pencils of light will be deflected by twice the angle of tilt (principle of reflection) and will be brought to focus in the

plane of the target graticule but linearly displaced from the actual target crosslines by an amount  $2\theta * f$ .

Linear displacement of the graticule image in the plane of the eyepiece is therefore directly proportional to reflector tilt and can be measured by an eyepiece graticule, optical micrometer or electronic detector system, scaled directly in angular units. The autocollimator is set permanently at infinity focus and no device for focusing adjustment for distance is provided or desirable. It responds only to reflector tilt (not lateral displacement of the reflector).

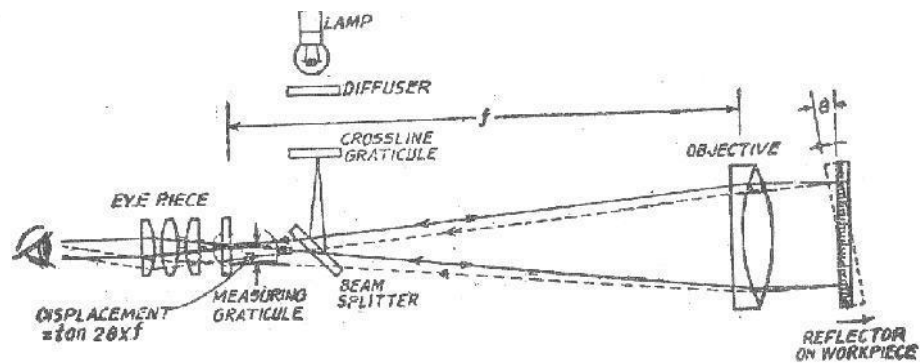

This is independent of separation between the reflector and the autocollimator, assuming no atmospheric disturbance and the use of a perfectly flat reflector. Many factors govern the specification of an autocollimator, in particular its focal length and its effective aperture. The focal length determines basic sensitivity and angular measuring range. The longer the focal length the larger is the linear displacement for a given reflector tilt, but the maximum reflector tilt which can be accommodated is consequently reduced. Sensitivity is

therefore traded against measuring range. The maximum separation between reflector and autocollimator, or "working distance", is governed by the effective aperture of the objective,

and the angular measuring range of the instrument becomes reduced at long working distances. Increasing the maximum working distance by increasing the effective aperture then demands a larger reflector for satisfactory image contrast. Autocollimator design thus involves many conflicting criteria and for this reason a range of instruments is required to optimally cover every application.

Air currents in the optical path between the autocollimator and the target mirror cause fluctuations in the readings obtained. This effect is more pronounced as distance from autocollimator to target mirror increases. Further errors may also occur due to errors in flatness and reflectivity of the target mirror which should be of high quality.

When both the autocollimator and the target mirror gauge can remain fixed, extremely close readings may be taken and repeatability is excellent. When any of these has to be moved, great care is required.

**Tests for straightness** can be carried out by using spirit level or auto-collimator.

The straightness of any surface could be determined by either of these instruments by measuring the relative angular positions of number of adjacent sections of the surface to be tested. So first a straight line is drawn on the surface whose straightness is to be tested. Then it is

divided into a number of sections, the length of each section being equal to the length of spirit level base or the plane reflector's base in case of auto-collimator. Generally the bases of the

spirit level block or reflector are fitted with two feet so that only feet have line contact with the surface and whole of the surface of base does not touch the surface to be tested. This ensures that angular deviation obtained is between the specified two points. In this case length of each section must be equal to distance between the centre lines of two feet. The spirit level can be used only for the measurement of straightness of horizontal surfaces while auto-collimator method can be used on surfaces in any plane. In case of spirit level, the block is moved along the line on the surface to be tested in steps equal to the pitch distance between the centre lines of the feet and the angular variations of the direction of block are measured by the sensitive level on it. Angular variation can be correlated in terms of the difference of height between two points by knowing the least count of level and length of the base.

In case of measurement by auto-collimator, the instrument is placed at a distance of 0.5 to 0.75 metre from the surface to be tested on any rigid support which is independent of the surface to be tested. The parallel beam from the instrument is projected along the length of the surface to be tested. A block fixed on two feet and fitted with a plane vertical reflector is placed on the surface and the reflector face is facing the instrument. The reflector and the instrument are set such that the image of the cross wires of the collimator appears nearer the centre of the field and for the complete movement of reflector along the surface straight line, the image of cross-wires will appear in the field of eyepiece. The reflector is then moved to the other end of the surface in steps equal to the centre distance between the feet and the tilt of the reflector is noted down in seconds from the eyepiece.

$$1 \text{ sec. of arc} = 0.000006 \text{ mm/mm}$$

Therefore, 1 sec. of arc will correspond to a rise or fall of  $0.000006 * l$  mm, where  $l$  is the distance between centres of feet in mm. The condition for initial and subsequent readings is shown in Fig. 7.2 in which the rise and fall of the surface is shown too much exaggerated.

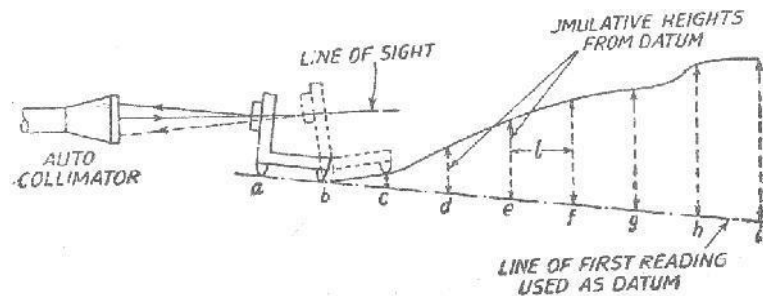

With the reflector set at a—b (1st reading), the micrometer reading is noted and this line is treated as datum line. Successive readings at b—c, c—d, d—e etc. are taken till the length of the surface to be tested has been stepped along. In order to eliminate any error in previous set of readings, the second set of readings could be taken by stepping the reflector in the reverse direction and mean of two taken. This mean reading represents the angular position of the reflector in seconds relative to the optical axis or auto-collimator.

Column 1 gives the position of plane reflector at various places at intervals of 'l' e.g. a—b, b—c, c—d etc., column 2 gives the mean reading of auto-collimator or spirit level in seconds. In column 3, difference of each reading from the first is given in order to treat first reading as datum. These differences are then converted into the corresponding linear rise or fall in column 4 by multiplying column 3 by 'l'. Column 5 gives the cumulative rise or fall, i.e.,

the heights of the support feet of the reflector above the datum line drawn through their first position. It should be noted that the values in column 4 indicate the inclinations only and are not errors from the true datum. For this the values are added cumulatively with due regard for sign. Thus it leaves a final displacement equal to  $L$  at the end of the run which of course does not represent the magnitude of error of the surface, but is merely the deviation from a straight line produced from the plane of the first reading. In column 5 each figure represents a point, therefore, an additional zero is put at the top representing the height of point  $a$ .

The errors of any surfaced may be required relative to any mean plane. If it be assumed that mean plane is one joining the end points then whole of graph must be swung round until the end point is on the axis (Fig. 7.3). This is achieved by subtracting the length  $L$

proportionately from the readings in column 5. Thus if  $n$  readings be taken, then column 6 gives the adjustments—  $L/n$ ,  $-2L/n$ ... etc., to bring both ends to zero. Column 7 gives the

difference of columns 5 and 6 and represents errors in the surface from a straight line joining the end points. This is as if a straight edge were laid along the surface profile to be tested and touching the end points of the surface when they are in a horizontal plane and the various readings in column 7 indicate the rise and fall relative to this straight edge.

### 4.3 Optical Flat:

1. Optical flats are flat lenses, made from quartz, having a very accurate surface to transmit light.
2. They are used in interferometers, for testing plane surfaces.
3. The diameter of an optical flat varies from 50 to 250mm and thickness varies from 12 to 25 mm.
4. Optical flats are made in a range of sizes and shapes.
5. The flats are available with a coated surface.
6. The coating is a thin film, usually titanium oxide, applied on the surface to reduce the light lost by reflection.
7. The coating is so thin that it does not affect the position of the fringe bands, but a coated flat

The supporting surface on which the optical flat measurements are made must provide a clean, rigid platform. Optical flats are cylindrical in form, with the working surface and are of two types are i) **type A**, ii) **type B**.

- ☐ **Type A:** It has only one surface flat and is used for testing flatness of precision measuring surfaces of flats, slip gauges and measuring tables.

For these optical flats, their diameter and grade are important. The dimensions of an optical flat of grades I and II can be 25 x 10, 30 x 10, 50 x 15, 75 x 20, 100 x 25, 125 x 30, 160 x 35 (diameter thickness in mm). The tolerance on flat should be 0.05  $\mu\text{m}$  for type A.

- ☐ **Type B:** It has both surfaces flat and parallel to each other. They are used for testing measuring surfaces of micrometers, measuring anvils and similar length of measuring devices for testing flatness and parallelism. For these instruments, their thickness and grades are important. The tolerances on flatness, parallelism and thickness should be 0.05  $\mu\text{m}$ .

#### Care in the use of optical flats:

- ☐ Before using, it should be ensured that the workpiece and flat are clean and free from dirt, dust and oil. Paper or chamois is used for polishing their surfaces.
  - ☐ Optical flats should never be slid over the workpiece but lifted from it. Sliding, creeping and wringing of flat over workpiece are extremely harmful and should be avoided.
3. Flats should never be wrung on workpiece because it scratches readily. It should be rested carefully on the workpiece.



- If interference bands are not good, flat should be lifted and set down again, applying vertical finger pressure at various locations on the upper surface to obtain satisfactory bands.

### Interference Bands by Optical Flat:

Optical flats are blocks of glass finished to within 0.05 microns for flatness. When an optical flat is on a flat surface which is not perfectly flat, then the optical flat will not exactly coincide with it, but it will make an angle  $\theta$  with the surface as shown in Figure

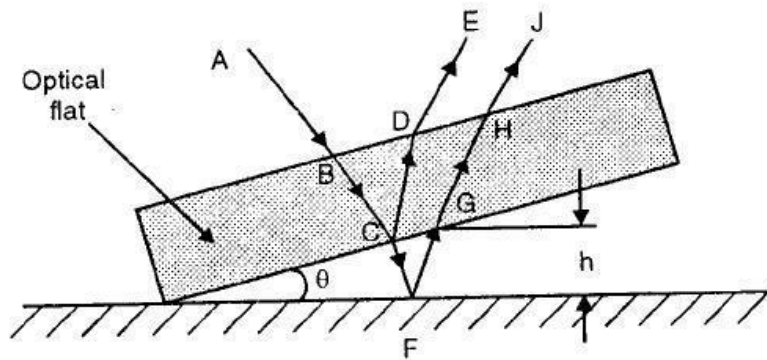

When a beam AB of monochromatic light falls on the optical flat, it travels further along BC. At C, part of this light is reflected by the bottom of the optical flat and goes along CDE, the remaining part goes along CF, reflected at F by the surface under test and goes further along FGHJ. The two beams DE and HJ differ in phase because of the extra distance

CFG traveled by HJ. If the air gap between the bottom of the optical flat and the test surface is denoted by 'h' since  $\theta$  is very small, then for vertically incident beams  $h = CF = FG = (\lambda /$

4) where  $\lambda$  = wavelength of source and thus beam HJ will lag behind DE by  $2h$ . When this lag is half the wavelength, the two beams DE and HJ will be in opposite phase and a state of

darkness will be created. At all points where the air gap is present then darkness will be created. At all points where the air gap is present then darkness will be observed at  $\lambda / 2$

distance as shown in Figure

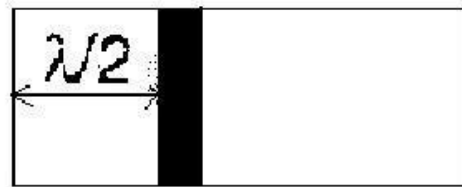

In other words, all points with air gap  $h$  will form a dark band. As we move along the

wedge to the right side, to point K, L, value of  $h$  goes on increasing and hence the phase difference between the two rays will go on increasing from  $\lambda/2$  and will reach  $A$  at some

point. At these points as the air gap increases, for every  $\sim$  increase, the bright bands will be seen as shown in Figure

**To check the flatness of slip gauge surface using optical flat:**

The apparatus required is a monochromatic light source and optical flat. If optical flat is placed on slip gauge, it will not form an intimate contact, but will be at some angle ' $\theta$ '

making an inclined plane. If the optical flat is illuminated by monochromatic light and eye is placed in proper position will observe number of bands. They are produced by interference of light rays reflected from lower plane of optical flat and top surface of slip gauge

They are produced by interference of light rays reflected from lower plane of optical flat and top surface of slip gauge. As shown in Figure, if 'S' is monochromatic light source. At 'C' ray is reflected in direction CDE. The two reflected components are combined by eye, having traveled path whose wavelengths differ by an amount ACD. If path lengths differ by odd number of  $\lambda/2$  then interference is said to have occurred. If surface is perfectly flat then

the surface will be crossed by the pattern of alternate light and dark bands which will be straight and dark line is seen passing at C. The next line occurs at  $3\lambda / 2$  (i.e.  $FHI = 3\lambda / 2$ )

alternate dark and bright fringes are seen and variation from the straightness of the bands measure the error in the flatness of slip gauge

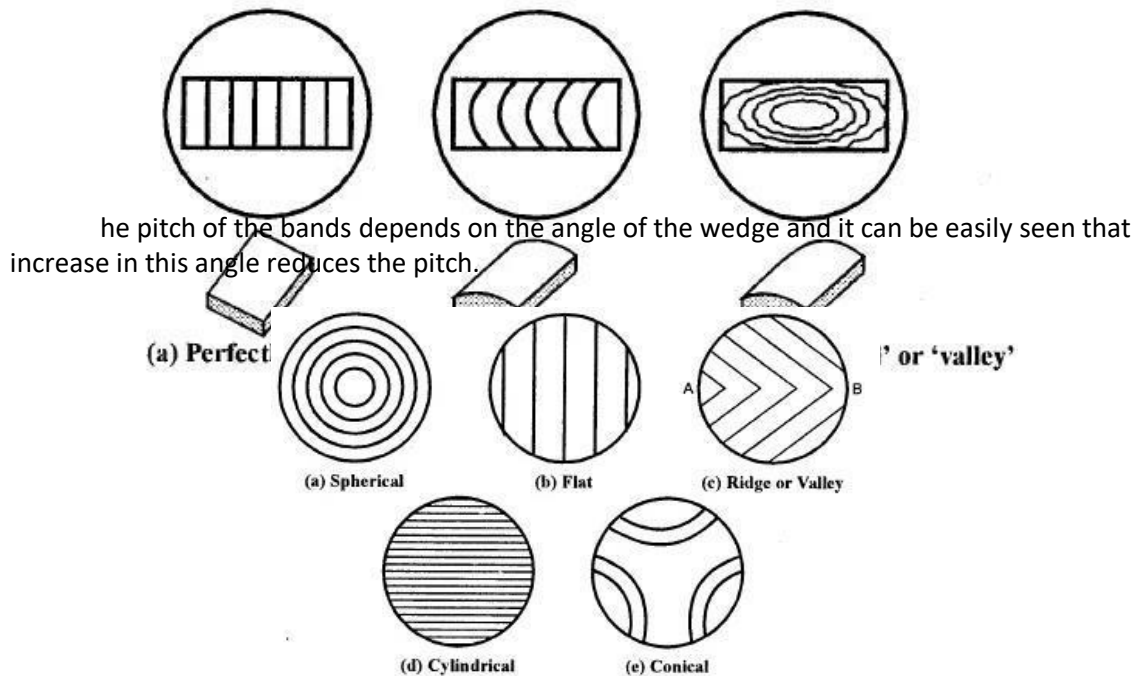

The orientation of the bands depends on the orientation of the wedge. The spherical surface can be concave or convex and a little pressure on the optical flat at the centre will spread the bands outwards in a convex way. Figure shows interference band patterns on various surfaces. This fact can be used for drawing various conclusions about the nature of the surface by applying pressure on the optical flat at various points and observing the change in the pattern of bands.

**Concave and Convex Surface:**

If AB is the line of contact then a general rule to identify the concave and convex surface is that if the band curve is around the point or line of contact, then the surface is convex and if the band curve is in the opposite direction then the surface is concave.

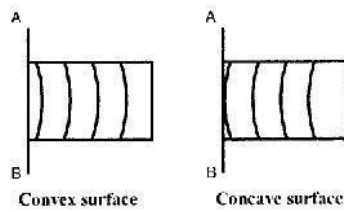

Spherical concave and convex surface can be identified by the following Figures.

**a. Convex surfac**

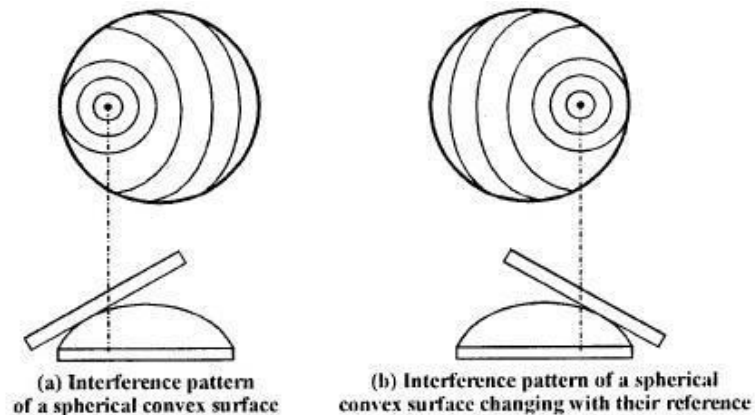

**b. Concave Surface:**

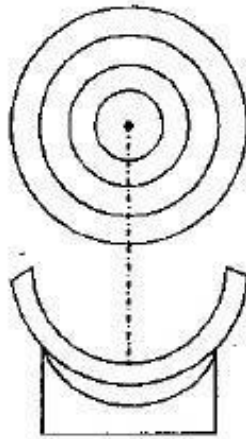

**Checking of heights and Parallelism of Slip gauge with Optical Flat:** The standard gauge and the gauge under test have their ends perfectly flat and parallel, they differ in length by the amount 'h' shown, which may be a few microns. The experiment aims at finding the value of h. The standard and the gauge are wrung on to a perfectly flat lapped base. The optical flat is placed in good contact but not wrung to the gauge tops. The orientation of the flat is adjusted till pattern of bands parallel to the sides of the gauges is obtained.

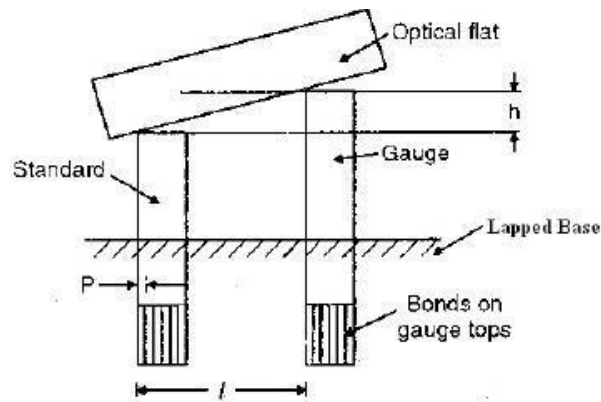

Comparison of End Gauges

The distance  $l$  is noted down and the pitch  $P$  of the bands is found by counting the, total number of bands on the gauge faces. As each band represents a air gap change of  $\lambda/2$ , the value of  $h$  will be  $(l / p) \lambda/2$

Whether the length of the gauge is more or less than the master, can be found out by observing the change in the pitch of the bands on the two gauges, when a little pressure is applied at the centre of the flat.

An experimental method of comparing two end gauges is more of academic interest, than of any practical value is show Figure. In the situation shown in the Figure such pressure will decrease the wedge angle with standard and increase it with the gauge, thereby making the bands on the standard, wider and those on the gauge, narrower. Also the parallelism between the gauge and standard can be observed with optical flat. The variation in the band can be seen as shown in Figure.

#### 4.5 Screw Threads Terminology:

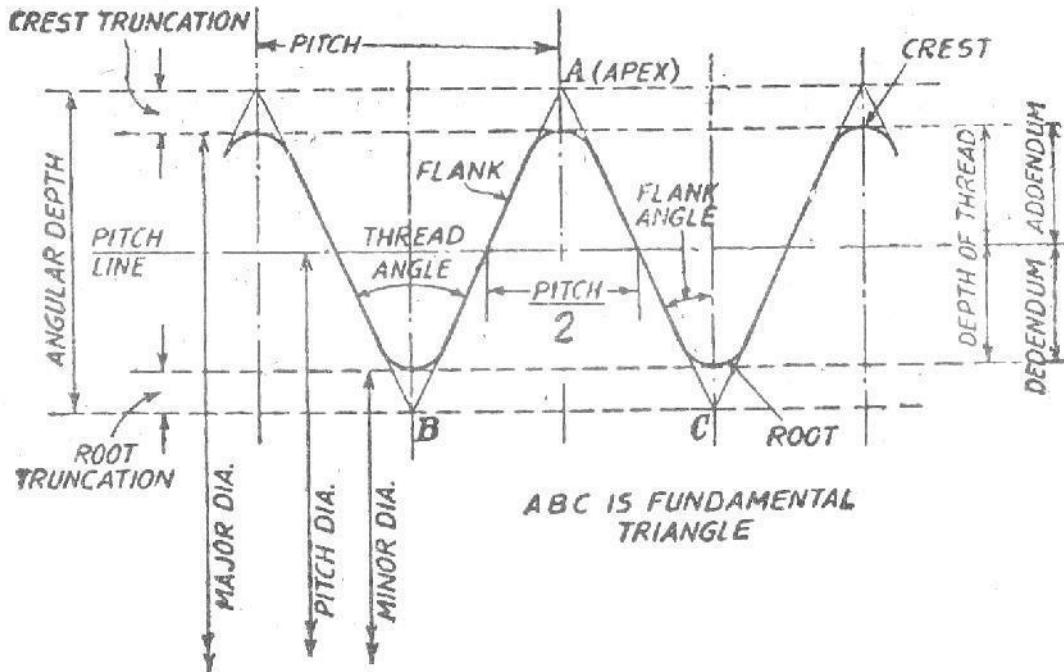

1. **Screw thread.** A screw thread is the helical ridge produced by forming a continuous helical groove of uniform section on the external or internal surface of a cylinder or cone. A screw thread formed on a cylinder is known as straight or parallel screw thread, while the one formed on a cone or frustum of a cone is known as tapered screw thread.
2. **External thread.** A thread formed on the outside of a workpiece is called external thread e.g., on bolts or studs etc.

3. **Internal thread.** A thread formed on the inside of a workpiece is called internal thread e.g. on a nut or female screw gauge.
4. **Multiple-start screw thread.** This is produced by forming two or more helical grooves, equally spaced and similarly formed in an axial section on a cylinder. This gives a 'quick traverse' without sacrificing core strength.
5. **Axis of a thread.** This is imaginary line running longitudinally through the centre of the screw.
6. **Hand (Right or left hand threads).** Suppose a screw is held such that the observer is looking along the axis. If a point moves along the thread in clockwise direction and thus moves away from the observer, the thread is right hand ; and if it moves towards the observer, the thread is left hand.



7. **Form, of thread.** This is the shape of the contour of one- complete thread as seen in axial section.
8. **Crest of thread.** This is defined as the prominent part of thread, whether it be external or internal.
9. **Root of thread.** This is defined as the bottom of the groove between the two flanks of the thread, whether it be external or internal.
10. **Flanks of thread.** These are straight edges which connect the crest with the root.
11. **Angle of thread {Included angle}.** This is the angle between the flanks or slope of the thread measured in an axial plane.
12. **Flank angle.** The flank angles are the angles between individual flanks and the perpendicular to the axis of the thread which passes through the vertex of the fundamental triangle. The flank angle of a symmetrical thread is commonly termed as the half- angle of thread.
13. **Pitch.** The pitch of a thread is the distance, measured parallel to the axis of the thread, between corresponding points on adjacent thread forms in the same axial plane and on the same side of axis. The basic pitch is equal to the lead divided by the number of thread starts. On drawings of thread sections, the pitch is shown as the distance from the centre of one thread crest to the centre of the next, and this representation is correct for single start as well as multi-start threads.
14. **Lead.** Lead is the axial distance moved by the threaded part, when it is given one complete revolution about its axis with respect to a fixed mating thread. It is necessary to distinguish between measurements of lead from measurement of pitch, as uniformity of pitch measurement does not assure uniformity of lead. Variations in either lead or pitch cause the functional or virtual diameter of thread to differ from the pitch diameter.
15. **Thread per inch.** This is the reciprocal of the pitch in inches.
16. **Lead angle.** On a straight thread, lead angle is the angle made by the helix of the thread at the pitch line with plane perpendicular to the axis. The angle is measured in an axial plane.
17. **Helix angle.** On straight thread, the helix angle is the angle made by the helix of the thread at the pitch line with the axis. The angle is measured in an axial plane.
18. **Depth of thread.** This is the distance from the crest or tip of the thread to the root of the thread measured perpendicular to the longitudinal axis or this could be defined as the distance measured radially between the major and minor cylinders.
19. **Axial thickness.** This is the distance between the opposite faces of the same thread measured on the pitch cylinder in a direction parallel to the axis of thread.

20. **Fundamental triangle.** This is found by extending the flanks and joining the points B and C. Thus in Fig. 13.2, triangle ABC is referred to as fundamental triangle. Here BC=pitch and the vertical height of the triangle is called the angular or theoretical depth. The point A is the apex of the triangle ABC.
21. **Truncation.** A thread is sometimes truncated at the crest or at the root or at both crest and root. The truncation at the crest is the radial distance from the crest to the nearest apex of the fundamental triangle. Similarly the truncation at the root is the radial distance from the root to the nearest apex.
22. **Addendum.** For an external thread, this is defined as the radial distance between the major and pitch cylinders. For an internal thread this is the radial distance between the minor and pitch cylinders.

23. **Dedendum.** This is the radial distance between the pitch and minor cylinder foreexternal thread, and for internal thread, this is the radial distance between the major and pitch cylinders.
24. **Major diameter.** In case of a straight thread, this is the diameter of the major cylinder (imaginary cylinder, co-axial with the screw, which just touches the crests of an external thread or the root of an internal thread). It is often referred to as the outside diameter, crest diameter or full diameter of external threads.
25. **Minor diameter.** In case of straight thread, this is the diameter of the minor cylinder (an imaginary cylinder, co-axial with the screw which just touches the roots of an external thread or the crest of an internal thread). It is often referred to as the root diameter or cone diameter of external threads.
26. **Effective diameter or pitch diameter.** In case of straight thread, this is the diameter of the pitch cylinder (the imaginary cylinder which is co-axial with the axis of the screw, and intersects the flank of the threads in such a way as to make the width of threads and width of the spaces between the threads equal). If the pitch cylinder be imagined as generated by a straight line parallel to the axis of screw, that straight line is then referred to as the pitch line. Along the pitch line, the widths of the threads and the widths of the spaces are equal on a perfect thread. This is the most important dimension as it decides the quality of the fit between the screw and the nut.
27. **Functional (virtual) diameter.** For an external or internal thread, this is the pitch diameter of the enveloping thread of perfect pitch, lead and flank angles having full depth of engagement but clear at crests and roots. This is defined over a specified length of thread. This may be greater than the simple effective diameter by an amount due to errors in pitch and angle of thread. The virtual diameter being the modified effective diameter by pitch and angle errors, is the most important single dimension of a screw thread gauge.

In the case of taper screw thread, the cone angle of taper, for measurement of effective diameter, and whether pitch is measured along the axis or along the pitch cone generator also need to be specified.

#### Measurement of screw threads- principles of floating carriage micrometer,

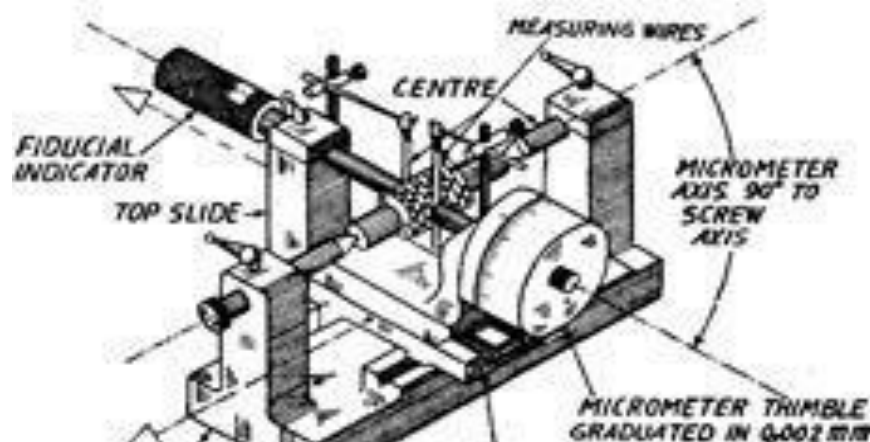

It consists of three main units. A base casting carries a pair of centres, on which the threaded work-piece is mounted. Another carriage is mounted on it and is exactly at  $90^\circ$  to it. On this is provided another carriage capable of moving towards the centres. On this carriage one head having a large thimble enabling reading upto 0.002 mm is provided. Just opposite to it is a fixed anvil which is spring loaded and its zero position is indicated by a fiducial indicator. Thus the micrometer elements are exactly perpendicular to the axis of the centres as the two carriages are located perpendicular to each other. On the fixed carriage the centres are supported in two brackets fitted on either end. The distance between the two centres can be adjusted depending upon the length of the threaded job. After job is fitted between the centres the second carriage is adjusted in correct position to take measurements and is located in position. The third carriage is then moved till the fiducial indicator is against the set point. The readings are noted from the thimble head. It is now obvious that the axis of the indicator and micrometer head spindle is same and is perpendicular to the line of two centres. The indicator is specially designed for this class of work and has only one index line, against which the pointer is always to be set. This ensures constant measuring pressure for all readings. Sufficient friction is provided by the conical pegs to restrain the movement of carriage along the line of centres. The upper carriage is free to float on balls and enables micrometer readings to be taken on a diameter without restraint. Squareness of the micrometer to the line of centre can be adjusted by rotating the pegs in the first carriage which is made eccentric in its mounting.

Above the micrometer carriage, two supports are provided for supporting the wires and Vee-pieces for measurement of effective diameter etc.

#### **(i) Measurement of Major Diameter.**

For the measurement of major diameter of external threads, a good quality hand micrometer is quite suitable. In taking readings, a light pressure must be used as the anvils make contact with the gauge at points only and otherwise the errors due to compression can be introduced. It is, however, also desirable to check the micrometer reading on a cylindrical standard of approximately the same size, so that the zero error etc., might not come into picture.

For greater accuracy and convenience, the major diameter is measured by bench micrometer. This instrument was designed by N.P.L. to estimate some deficiencies inherent in the normal hand micrometer. It uses constant measuring pressure and with this machine the error due to pitch error in the micrometer thread is avoided. In order that all measurements be made at the same pressure, a fiducial indicator is used in place of the fixed anvil. In this machine there is no provision for mounting the workpiece between the centres and it is to be held in hand. This is so, because, generally the centres of the workpiece are not true with its diameter. This machine is used as a comparator in order to avoid any pitch errors of micrometers, zero error setting etc. A calibrated setting cylinder is used as the setting standard.

The advantage of using cylinder as setting standard and not slip gauges etc., is that it gives greater similarity of contact at the anvils. The diameter of the setting cylinder must be nearly same as the major diameter. The cylinder is held and the reading of the micrometer is noted down. This is then replaced by threaded workpiece and again micrometer reading is noted for the same reading of fiducial indicator. Thus, if the size of cylinder is approaching, that of major diameter, then for a given reading the micrometer thread is used over a short length of travel and any pitch errors it contains are virtually eliminated.

Then major diameter= $D_1+(R_2-R_1)$ .

In order- to determine the amount of taper, the readings should' be taken at various positions along the thread and to detect the ovality, two or three readings must be taken at one plane in angular positions.

**(ii) Measurement of Minor Diameter**

This is also measured by a comparative process using small Vee-pieces which make

contact with a root of the thread. The Vee-pieces are available in several sizes having suitable radii at the edges. The included angle of Vee-pieces is less than the angle of the thread to be checked so that it can easily probe to the root of the thread. To measure the minor diameter by Vee-pieces is suitable for only Whitworth and B.A. threads which have a definite radius at the root of the thread. For other threads, the minor diameter is measured by the projector or microscope.

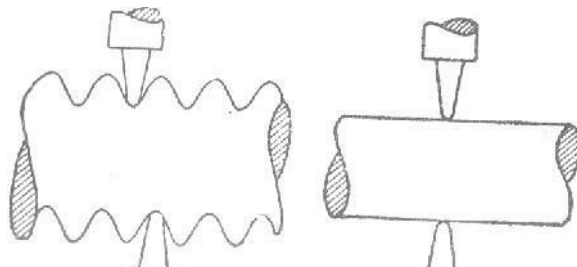

The measurement is carried out on a floating carriage diameter measuring machine in which the threaded work-piece is mounted between centres and a bench micrometer is constrained to move at right angles to the axis of the centre by a Vee-ball slide. The method of the application of Vee-pieces in the machine is shown diagrammatically in Fig.. The dimensions of Vee-pieces play no important function as they are interposed between the micrometer faces and the cylindrical standard when standard reading is taken.

It is important while taking readings, to ensure that the micrometer be located at right angles to the axis of the screw being measured. The selected Vees are placed on each side of the screw with their bases against the micrometer faces. The micrometer head is then advanced until the pointer of the indicator is opposite the zero mark, and note being made of the reading. The screw is then replaced by standard reference disc or a plain cylindrical standard plug gauge of approximately the core diameter of the screw to be measured and second reading of the micrometer is taken.

If reading on setting cylinder with Vee-pieces in position =  $R_1$   
 and reading on thread =  $R_2$

and diameter of setting cylinder =  $D_1$   
 Then minor diameter =  $D_1 + (R_2 - R_1)$

Readings may be taken at various positions in order to determine the taper and ovality.

**(iii) Effective Diameter Measurements.**

The effective diameter or the pitch diameter can be measured by any one of the following methods :

- (i) The micrometer method
- (ii) The one wire, two wire, or three wire or rod method.

**Two Wire Method.**

The effective diameter of a screw thread may be ascertained by placing two wires or rods of identical diameter between the flanks of the thread, as shown in Fig. 13.15, and measuring the distance over the outside of these wires. The effective diameter  $E$  is then calculated as

$$E = T + P$$

Where  $T$  = Dimension under the wires =  $M - 2d$

$M$  = dimension over the wires,  $d$  = diameter of each wire

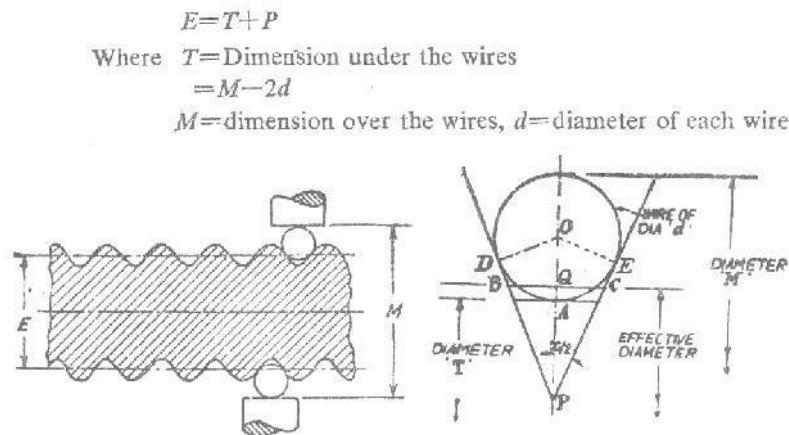

**Fig (a)**

**Fig (b)**

The wires used are made of hardened steel to sustain the wear and tear in use. These are given a high degree of accuracy and finish by lapping to suit different pitches.

Dimension T can also be determined by placing wires over a standard cylinder of diameter greater than the diameter under the wires and noting the reading  $R_1$  and then taking reading with over the gauge, say  $R_2$ . Then  $T = S - (R_1 - R_2)$ .

P=It is a value which depends upon the dia of wire and pitch of the thread.

If P= pitch of the thread, then

$$P = 0.9605p - 1.1657d \text{ (for Whitworth thread).}$$

$$P = 0.866p - d \text{ (for metric thread).}$$



Actually P is a constant Value which has to be added to the diameter under the wires to give the effective diameter. The expression for the value of P in terms of p (pitch), d (diameter of wire) and x (thread angle) can be derived as follows :

In Fig.13.15(b), since BC lies on the effective diameter line

$$BC = \frac{1}{2} \text{ pitch} = \frac{1}{2} p$$

$$OP = d \operatorname{cosec} \frac{x}{2}$$

$$PA = d(\operatorname{cosec} \frac{x}{2} - 1)/2$$

$$PQ = QC \cot \frac{x}{2} = p/4 \cot \frac{x}{2}$$

$$AQ = PQ - AP = p \cot \frac{x}{2} / 4 - d(\operatorname{cosec} \frac{x}{2} - 1)/2$$

AQ is half the value of P

$$\therefore P \text{ value} = 2AQ$$

$$= p/2 \cot \frac{x}{2} - d(\operatorname{cosec} \frac{x}{2} - 1)$$

Two wire method can be carried out only on the diameter measuring machine described for measuring the minor diameter, because alignment is not possible by 2 wires and can be provided only by the floating carriage machine. In the case of three wire method, 2 wire, on one side help in aligning the micrometer square to the thread while the third placed on the other side permits taking of readings.

#### 4.6 Three Wire Method.

This method of measuring the effective diameter is an accurate method. In this three wires or rods of known diameter are used ; one on one side and two on the other side {Fig. 13.17 (a) and (&)}. This method ensures the alignment of micrometer anvil faces parallel to the thread axis. The wires may be either held in hand or hung from a stand so as to ensure freedom to the wires to adjust themselves under micrometer pressure.

$M$ =distance over wires       $E$ =effective diameter

$r$ =radius of the wires       $d$ =diameter of wires

$h$  =height of the centre of the wire or rod from the effective  
effective  $x$ =angle of thread.

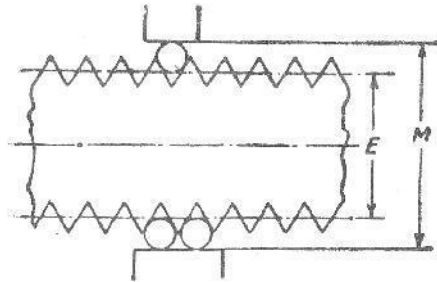

**Fig (a)**

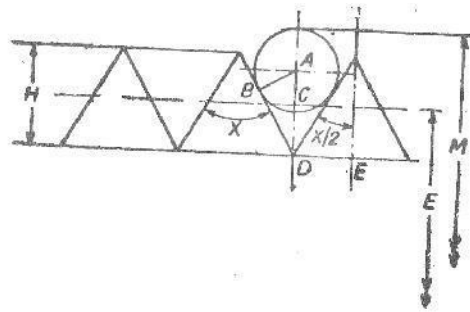

**Fig (b)**

From fig.(b),

$$AD = AB \operatorname{cosec} \frac{\alpha}{2} = r \operatorname{cosec} \frac{\alpha}{2}$$

$$H = DE \cot \frac{\alpha}{2} = \frac{p}{2} \cot \frac{\alpha}{2}$$

$$CD = \frac{1}{2}H = \frac{p}{4} \cot \frac{\alpha}{2}$$

$$H = AD - CD$$

$$r = \operatorname{cosec} \frac{\alpha}{2} - \frac{p}{4} \cot \frac{\alpha}{2}$$

$$\text{Distance over wires} = M = E + 2h + 2r$$

$$= E + 2\left(r \operatorname{cosec} \frac{\alpha}{2} - \frac{p}{4} \cot \frac{\alpha}{2}\right) + 2r$$

$$= E + 2r \left(1 + \operatorname{cosec} \frac{\alpha}{2}\right) - \frac{p}{2} \cot \frac{\alpha}{2}$$

$$\text{or } M = E + d \left(1 + \operatorname{cosec} \frac{\alpha}{2}\right) - \frac{p}{2} \cot \frac{\alpha}{2}$$

(since  $2r = 0$ )

**(i) In case of Whitworth thread:**

$\alpha = 55^\circ$ , depth of thread =  $0.64 p$ , so that

$$E = D - 0.64 p \text{ and } \operatorname{cosec} \frac{\alpha}{2} = 2.1657$$

$$\cot \frac{\alpha}{2} = 1.921$$

$$M = E + d \left(1 + \operatorname{cosec} \frac{\alpha}{2}\right) - \frac{p}{2} \cot \frac{\alpha}{2}$$

$$= D - 0.64p + d(1 + 2.1657) - p/2(1.921)$$

$$= D + 3.1657d - 1.6005p$$

$$M = D + 3.1657d - 1.6p$$

where  $D$  = outside dia.

**(ii) In case of metric threads:**

$$\text{Depth of thread} = 0.6495p$$

so,  $E = D - 0.6495p.$

$$x = 60^\circ, \operatorname{cosec} x/2 = 2; \cot x/2 = 1.732$$

$$M = D - 0.6495p + d(1 + 2) - p/2(1.732)$$

$$= D + 3d - (0.6495 + 0.866)p$$

$$= D + 3d - 1.5155p.$$

We can measure the value of  $M$  practically and then compare with the theoretical values with the help of formulae derived above. After finding the correct value of  $M$  and knowing  $d$ ,  $E$  can be found out.

If the theoretical and practical values of M (i.e. measured over wires) differ, then this error is due to one or more of the quantities appearing in the formula.

**Effect of lead angle on measurement by 3- wire method.** If the lead angle is large (as with worms; quick traversing lead screw, etc.) then error in measurement is about 0.0125 mm when lead angle is 41° for 60° single thread series.

For lead angles above 4°, the compensation for rake and compression must also be taken into account.

There is no recommendation for **B.S.W.** threads.

Rake Correction in U.S. Standard :

$$E = M + \cot \frac{\alpha}{2} \frac{d}{2n} - \frac{d}{2} \left( 1 + \operatorname{cosec} \frac{\alpha}{2} + \frac{s^2}{2} \cos \frac{\alpha}{2} \cot \frac{\alpha}{2} \right)$$

where

$\alpha/2$  = half the included angle of threads.

E = effective diameter

M = actually measured diameter over wires:

n = number of threads/inch.

d = diameter of wire.

S = tangent of the helix angle in thread.

### **Best size wire Method.**

This wire is of such diameter that it makes contact with the flanks of the thread on the effective diameter or pitch line. The effective diameter can be measured with any diameter

wire which makes contact on the true flank of the thread, but the values so obtained will differ from those obtained with 'best size' wires if there is any error in angle or form of

thread. It is recommended that for measuring the effective diameter, always the best size wire should be used and for this condition the wire touches the flank at mean diameter line within  $\pm 1/5$  of flank length

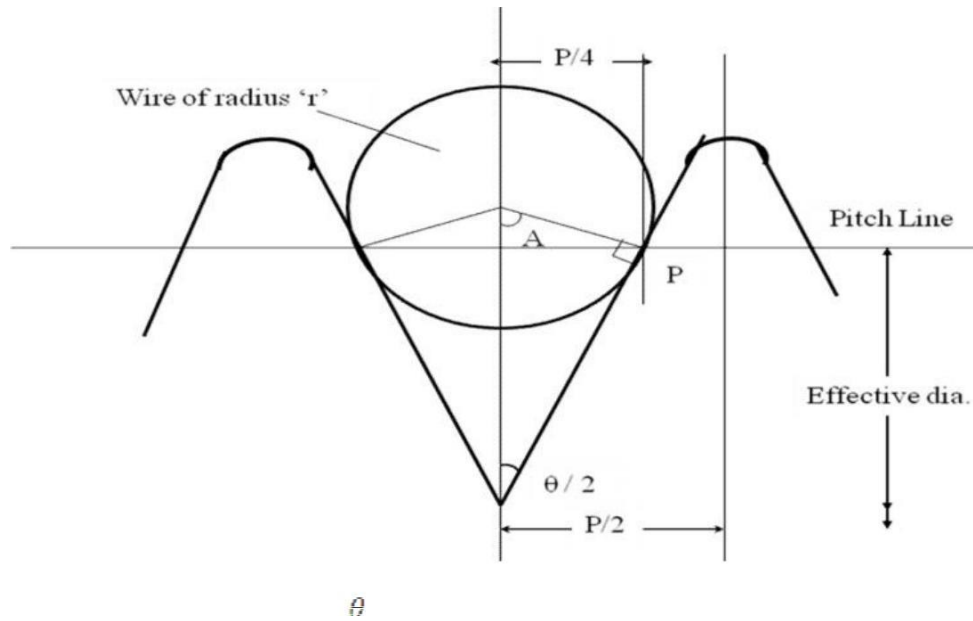

Let the thread angle be  $\frac{\theta}{2}$

Then in  $\Delta$ le OAP,  $\sin \text{POA} = \frac{AP}{OP}$

Or  $\sin(90^\circ - \frac{\theta}{2}) = \frac{AP}{OP}$

$OP = \frac{AP}{\sin(90^\circ - \frac{\theta}{2})} = \frac{AP}{\cos \frac{\theta}{2}} = AP \sec \frac{\theta}{2}$

Since,  $OP = r = AP \sec \frac{\theta}{2}$

And wire diameter =  $D_b = 2r = 2AP \sec \frac{\theta}{2}$

Since AP lies on the pitch line

$AP = \frac{p}{4}$  where, p is the pitch of the thread

Therefore,  $D_b = \frac{p}{2} \sec \frac{\theta}{2}$

Therefore,  $D_b = \frac{p}{2} \sec \frac{\theta}{2}$

### 4.7 Tool Makers Microscope:

The toolmaker's microscope is an optical measuring machine equipped for external and internal length measurements as well as measurements on screw threads, profiles, curvatures and angles. For these purposes, the microscope is provide with several measuring attachments such as

1. Centre stage for mounting of cylindrical components,
2. Revolving and angle measuring oculars,
3. Double image ocular,
4. Optical feeder, and
5. Projection screen.

The applications of the instrument may be summarized lows: broadly as follows.

1. The determination of the relative position of various Points on work by measuring the travel necessary to bring a second point to the position previously occupied by the first, and so on. .
2. Measurement of angles by using a protractor eye-piece.
3. Comparison of thread forms with master profiles engraved in the eyepiece and measurement of pitch and effective diameter.
4. Comparison of an enlarged, projected image with a scale tracing fixed to the projection screen.

Figure shows a toolmaker's microscope. The main parts of the instrument are:

1. Rotatable table
2. Swingable head
3. Projection screen
4. Objective lens
5. Measuring stage
6. Ocular
7. Micrometers
8. Prism.



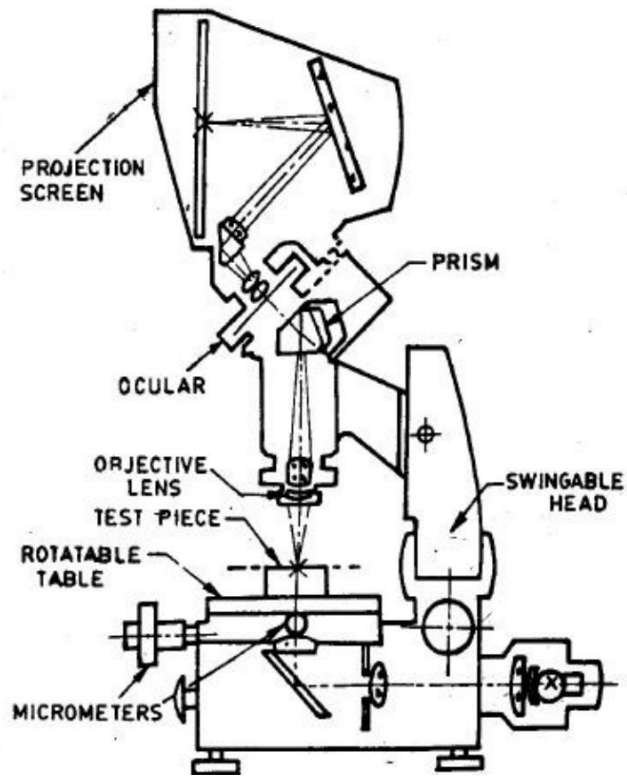

Construction:

The microscope consists of a rigid stand on which a swingable head is mounted. The measuring stage moves on ball guideways by actuating two measuring micrometers arranged perpendicular to each other in the length and the cross-sections. The measuring range of each micrometer is 25 mm and the measuring capacity can be increased using slip gauges. A rotatable table is provided over the stage, on which the workpiece can be fixed either directly or between centers. This table can be rotated through 360° and the angular rotation can be read by a fixed vernier to a scale value of 3'.

**Working:**

The component being measured is illuminated by the through light method. A parallel beam of light illuminates the lower side of workpiece which is then received by the objective lens in its way to a prism that deflects the light rays in the direction of the measuring ocular and the projection screen. Incident illumination can also be provided by an extra attachment. Exchangeable objective lens having magnification 1X, 1.5X, 3X and 5X are available so that a total magnification of 10X, 15X, 30 X and 50X can be achieved with an ocular of 10X. The direction of illumination can be tilted with respect to the workpiece by tilting the measuring head and the whole optical system. This inclined illumination is necessary in some cases as in screw thread measurements.

The scale value of this microscope:

- ② 0.01 mm for length measurement.
- ② 3' for angle measurement with rotatable table.
- ② 1' for angle measurement with the angle measuring ocular.

## Applications

The applications of the instrument may be summarized broadly as follows.

- (1) The determination of the relative position of various Points on work by measuring the travel necessary to bring a second point to the position previously occupied by the first, and so on.
- (2) Measurement of angles by using a protractor eye-piece.
- (3) Comparison of thread forms with master profiles engraved in the eyepiece and measurement of pitch and effective diameter.
- (4) Comparison of an enlarged, projected image with a scale tracing fixed to the projection screen.

## Gear Measurement

Gears is a mechanical drive which transmits power through toothed wheel. In this gear drive, the driving wheel is in direct contact with driven wheel. The accuracy of gearing is the very important factor when gears are manufactured. The transmission efficiency is almost 99 in gears. So it is very important to test and measure the gears precisely.

For proper inspection of gear, it is very important to concentrate on the raw materials, which are used to manufacture the gears, also very important to check the machining the blanks, heat treatment and the finishing of teeth.

The gear blank should be tested for dimensional accuracy (face width, bore, hub, length, and outside diameter), and eccentricity. As outside diameter forms the datum from where the tooth thickness is measured, it forms an important item to be controlled. Concentricity of the blanks is also essential and the side faces should be true to the bore. On very precise gears details like tip radius, shape of root provided and surface finish are also measured.

The most commonly used forms of gear teeth are

1. Involute
  2. Cycloidal
- ☐ The involute gears also called as straight tooth or spur gears.
  - ☐ The cycloidal gears are used in heavy and impact loads.
  - ☐ The involute rack has straight teeth.
  - ☐ The involute pressure angle is either  $20^\circ$  or  $14.5^\circ$

## Types of gears

### 1. Spur gear:-

- ☐ Cylindrical gear whose tooth traces is straight line.
- ☐ These are used for transmitting power between parallel shafts.

## 2. Spiral gear :-

- ☐ The tooth of the gear traces curved lines.

## 3. Helical gears:-

- ☐ These gears used to transmit the power between parallel shafts as well as non-parallel and non-intersecting shafts.
- ☐ It is a cylindrical gear whose tooth traces is straight line.

## 4. Bevel gears:-

- ☐ The tooth traces are straight-line generators of cone.
- ☐ The teeth are cut on the conical surface. It is used to connect the shafts at right angles.

## 5. Worm and Worm wheel :

- ☐ It is used to connect the shafts whose axes are non-parallel and non-intersecting.

## 6. Rack and Pinion:-

- ☐ Rack gears are straight spur gears with infinite radius.

## 4.8 Gear Tooth Nomenclature

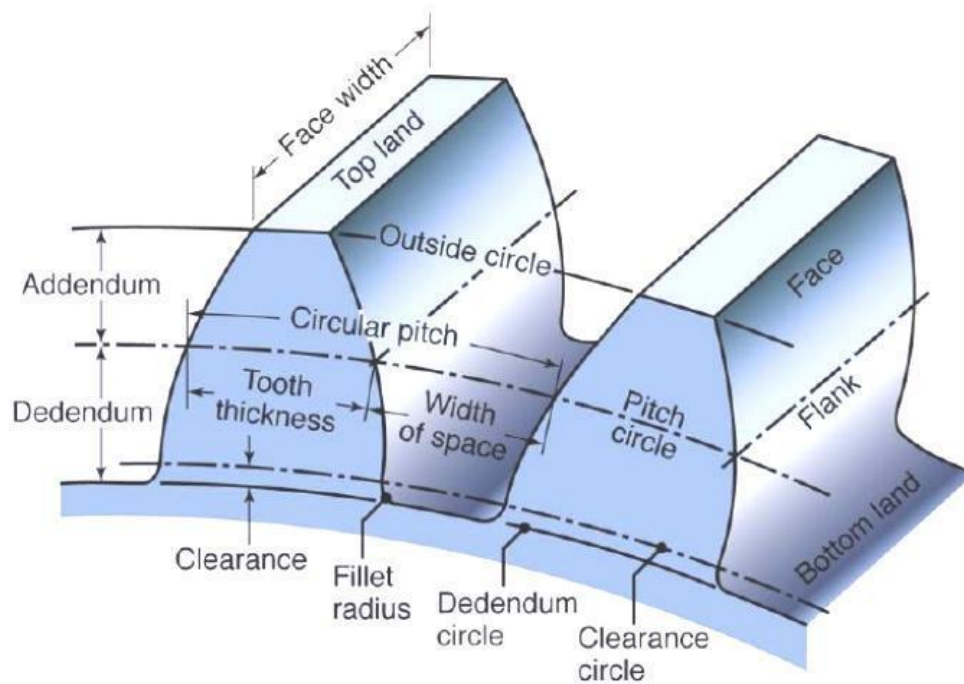

**1. Tooth profile:**

- ☐ It is the shape of any side of gear tooth in its cross section.

**2. Base circle:**

- ☐ It is the circle of gear from which the involute profile is derived.
- ☐ Base circle diameter = Pitch circle diameter  $\times$  Cosine of pressure angle of gear

**3. Pitch circle diameter (PCD):**

- ☐ The diameter of a circle which will produce the same motion as the toothed gear wheel

**4. Pitch circle**

- ☐ It is the imaginary circle of gear that rolls without slipping over the circle of its mating gear.

**5. Addendum circle:**

- ☐ The circle coincides with the crests (or) tops of teeth.

**6. Dedendum circle (or) Root circle:**

- ☐ This circle coincides with the roots (or) bottom of teeth.

**7. Pressure angle (a):**

- ☐ It is the angle making by the line of action with the common tangent to the pitch circles of mating gears.

**8. Module (m):**

- ☐ It is the ratio of pitch circle diameter to the total number of teeth.

$$m = \frac{d}{n}$$

Where,  $d$  = Pitch circle diameter.

$n$  = Number of teeth

### 9. Circular pitch

It is the distance along the pitch circle between corresponding points of adjacent teeth

### 10. Addendum:

Radial distance between tip circle and pitch circle. Addendum value = 1 module.

### 11. Dedendum:

Radial distance between pitch circle and root circle, Dedendum value = 1.25 module.

### 12. Clearance (C):

A amount of distance made by the tip of one gear with the root of mating gear.  
Clearance = Difference between Dedendum and addendum values

### 13. Blank diameter:

The diameter of the blank from which gear is cut. Blank diameter = PCD + 2m

### 14. Face:

Part of the tooth in the axial plane lying between tip circle and pitch circle.

### 15. Flank:

Part of the tooth lying between pitch circle and root circle.

### 16. Top land:

Top surface of a tooth

**17. Lead angle:**

- ☐ The angle between the tangent to the helix and plane perpendicular to the axis of cylinder.

**18. Backlash:**

- ☐ The difference between the tooth thickness and the space into which it meshes.

**OUTCOMES**

Students will be able to

1. Understand the principle and working of autocollimeter, toolmakers microscope.
2. Know the concept of screw thread and 2 wire – 3 wire method.

**SELF ASSESSMENT QUESTIONS**

1. Describe the principle and operation of a Michelson Interferometer.
2. What are the uses and the advantages of a laser interferometer?
3. How is phase of light beam related to the fringes formed due to interference?
4. Explain the formation of white and dark fringes due to interference of light.
5. What are the differences between constructive and destructive interference?

**FURTHER READING**

1. Jain R. K., 1997, Engineering Metrology, Khanna Publishers.
2. Shawne A. K., 1998, Mechanical Measurement and Instrumentation, Dhanpat Rai and Co. (P) Ltd.
3. Hazra Chowdhury, 1995, Workshop Technology, Media Promoters and Publishers Pvt. Ltd