

## MODULE – 2

### HIGHWAY ALIGNMENT AND SURVEYS

#### Introduction

The position or the layout of the central line of the highway on the ground is called the alignment. Highway Alignment includes both

- a) Horizontal alignment includes straight and curved paths, the deviations and horizontal curves.
- b) Vertical alignment includes changes in level, gradients and vertical curves.

A new road should be aligned very carefully as improper alignment will lead to increase in construction, maintenance and vehicle operation cost. Once the road is aligned and constructed, it is not easy to change it due to increase in cost of adjoining land and construction of costly structures by the roadside

#### Requirements

The requirements of an ideal alignment are

- a) **Short:** The alignment between two terminal stations should be short and as far as possible be straight, but due to some practical considerations deviations may be needed.
- b) **Easy:** The alignment should be easy to construct and maintain. It should be easy for the operation of vehicles. So, to the maximum extent easy gradients and curves should be provided.
- c) **Safe:** It should be safe both from the construction and operating point of view especially at slopes, embankments, and cutting. It should be safe for traffic operation with safe geometric features.
- d) **Economical:** The alignment should be economical and it can be considered so only if the total life cycle cost considering the initial cost, maintenance cost, and vehicle operating cost is lowest.

**Factors Controlling Alignment**

For an alignment to be shortest, it should be straight between the two terminal stations, but this is not always possible due to various practical difficulties such as intermediate obstructions or topography. A road which is economical with low initial investment may not be the most economical in terms of maintenance or vehicle operation cost(VOC). Thus, it may be seen that an alignment can fulfil all the requirements simultaneously, hence a judicious choice is made considering all the factors.

The various factors that control the alignment are as follows:

- a) Obligatory Points
- b) Traffic
- c) Geometric Design
- d) Economics
- e) Other Considerations

**Obligatory Points**

These are the control points governing the highway alignment. These points are classified into two categories.

- 1) Points Through Which the Alignment Should Pass
- 2) Points Through Which the Alignment Should Not Pass.

**Points Through Which the Alignment Should Pass**

- a) Bridge site: The bridge can be located only where the river has straight and permanent path and also where the abutment and pier can be strongly founded. The road approach to the bridge should not be curved and skew crossing should be avoided as possible. Thus, to locate a bridge the highway alignment may be changed.
- b) Mountain: While the alignment passes through a mountain, the various alternatives are to either
- c) Construct a tunnel or to go around the hills. The suitability of the alternative depends on factors like topography, site conditions and construction and operation cost.
- d) Intermediate town: The alignment may be slightly deviated to connect an intermediate town or village nearby. These were some of the obligatory points through which the alignment should pass.

**Points Through Which the Alignment Should Not Pass.**

- a) Religious places: These have been protected by the law from being acquired for any purpose. Therefore, these points should be avoided while aligning.
- b) Very costly structures: Acquiring such structures means heavy compensation which would result in an increase in initial cost. So, the alignment may be deviated not to pass through that point.
- c) Lakes/ponds etc.: The presence of a lake or pond on the alignment path would also necessitate deviation of the alignment.

**Traffic**

The alignment should suit the traffic requirements. Based on the origin- destination data of the area, the desire lines should be drawn. The new alignment should be drawn keeping in view the desire lines, traffic flow pattern etc.

**Geometric design**

Geometric design factors such as gradient, radius of curve, sight distance etc. also governs the alignment of the highway. To keep the radius of curve minimum, it may be required to change the alignment of the highway. The alignments should be finalized such that the obstructions to visibility do not restrict the minimum requirements of sight distance. The design standards vary with the class of road and the terrain and accordingly the highway should be aligned.

**Economics**

The alignment finalized should be economical. All the three costs i.e. construction, maintenance, and operating cost should be minimum. The construction cost can be decreased much if it is possible to maintain a balance between cutting and filling. Also try to avoid very high embankments and very deep cuttings as the construction cost will be very higher in these cases.

**Other Considerations**

The various other factors that govern the alignment are drainage considerations, political considerations and monotony. The vertical alignment is often guided by drainage considerations such as sub surface drainage, water level, seepage flow, and high flood levels. A foreign territory coming across the alignment will necessitate the deviation of the horizontal alignment. In flat terrain, even though it is possible to have a very long stretch of road which is absolutely straight may be monotonous for driving. Hence it is recommended to have a slight bend or road side amenities to break monotony.

---

## ENGINEERING SURVEYS FOR HIGHWAY ALIGNMENT

### Stages of Engineering Surveys

Before a highway alignment is finalised in a new highway project, engineering surveys are to be carried out. These engineering surveys may be completed in the following four stages:

- a) Map Study
- b) Reconnaissance Survey
- c) Preliminary Surveys
- d) Final Location and Detailed Surveys

### Map Study

It is possible to suggest the likely routes of the roads if the topographic map of the area is available. In India, topographic maps are available from the Survey of India, with 15 or 30 metre contour intervals. The main features like rivers, hills valleys, etc. are also shown on these maps.

The probable alignment can be located on the map from the following details available on the map.

- Alignment avoiding valleys, ponds or lakes
- When the road has to cross a row of hills or mountains, possibility of crossing through a mountain pass.
- Approximate location of bridge site for crossing rivers, avoiding bend of the river, if any
- When a road is to be connected between two stations, one of the top and the other on the foot of the hill, then alternate routes can be suggested keeping in view the design or ruling gradient and the maximum permissible gradient

Thus, from the map study alternate routes can be suggested. It may also be possibly from map study to drop a certain route in view of any unavoidable obstructions or undesirable ground and map study gives a rough guidance of the routes to be further surveyed in the field.

### Reconnaissance Survey

The second stage of engineering surveys for highway alignment is the reconnaissance survey. During the reconnaissance, the engineer visits the site and examines the general characteristics of the area before deciding the most feasible routes for detailed studies. A field survey party may inspect a fairly broad stretch of land along the proposed alternative routes of the map in the field, very simple survey instruments are used by the reconnaissance party to collect additional details rapidly, but not accurately. All relevant details which are not available

in the map are collected and noted down. Some of the details to be collected during reconnaissance are given below

- a) Valleys, ponds, lakes, marshy land, ridge, hills, permanent structures and other obstructions along the route which are not available in the map
- b) Approximate values of gradient, length of gradients and radius of curves of alternate alignments.
- c) Number and type of cross drainage structures, maximum flood level and natural ground water level along the probable routes.
- d) Soil type along the routes from field identification tests and observation of geological features
- e) Sources of construction materials, water and location of stone quarries
- f) When the road passes through hilly or mountainous terrain, additional data regarding the geological formation, type of rocks, dip of strata, seepage flow etc. may be observed so as to decide the stable and unstable sides of the hill for highway alignment

A rapid reconnaissance of the area, especially when it is vast and the terrain is difficult and it may be done by aerial survey. From the details collected during the survey the alignment proposed may be altered or even changes completed.

### **Preliminary Survey**

The main objectives of the preliminary survey are

- To survey the various alternate alignment proposed after the reconnaissance and to collect all the necessary physical information and details of topography, drainage and soil
- To compare the different proposals in view of the requirements of a good alignment.
- To estimate quantity of earthwork materials and other construction aspects and to work out the cost of alternate proposals.

The preliminary survey may be carried out by of following methods

- a) Conventional approach, in which a survey party carries out surveys using the required field equipment, taking measurements, collecting topographical and other data and carrying out soil survey
- b) Rapid approach, by aerial survey taking the required aerial photographs and by photogrammetric methods and photo-interpretation techniques for obtaining the necessary topographic and other maps including details of soil and geology
- c) Modern techniques by use of Global Positioning System (GPS)

The procedure of the conventional methods of preliminary survey is given in following steps:

- a) Primary Traverse
- b) Topographical Features
- c) Levelling Work
- d) Drainage Studies and Hydrological Data
- e) Soil Survey
- f) Material Survey
- g) Traffic Studies Primary Traverse

### **Primary Traverse**

The first step in the preliminary survey is to establish the primary traverse, following the alignment recommended in the reconnaissance. For alternate alignments either secondary traverses or independent primary traverses may be necessary. As these traverses are open traverses and adjustment of errors is not possible later, the angles should be very accurately measured using a precision theodolite.

### **Topographic Features**

After establishing the centre lines of preliminary survey, the topographical features are recorded. All geographical and other man-made features along the traverse and for a certain width on either side are surveyed and plotted. The width to be surveyed is generally decided by the survey party, but the absolute minimum width is the land width of the proposed alignment.

### **Levelling work**

Levelling work is also carried out side by side to give the centre line profiles and typical cross sections. Permanent and temporary bench marks should be first established at appropriate locations and the levels should be connected to the GTS datum. The levelling work in the preliminary survey is kept to a minimum just sufficient to obtain the approximate earth work in the alternate alignments. To draw contours of the strip of land to be surveyed, cross section levels should be taken at suitable intervals, generally 100 to 200 m in plain terrain, up to 50 m in rolling terrain and up to 30 m in hilly terrain.

### **Drainage Studies and Hydrological Data**

Drainage investigations and hydrological data are collected so as to estimate the type, number and approximate size of cross drainage structures. Also, the vertical alignment of the highway, particularly the grade line is decided based on the hydrological and drainage data, such as HFL, ponded water level, depth of water table, amount of surface runoff, etc.

**Soil Survey**

Soil survey is an essential part of the preliminary survey as the suitability of the proposed location is to be finally decided based on the soil survey data. The soil survey conducted at this stage also helps in working out details of earth work, slopes, suitability of materials, subsoil and surface drainage requirements and pavement type and the approximate thickness requirements. All these details are required to make a comparative study of alternate proposals. A detailed soil survey is not necessary. Post-hole auger or any other suitable types of hand augers may be used depending on the soil type to collect the soil sample up to a depth of 1 to 3 metre below the likely finished road level or the existing ground level, whichever is lower. When the road is expected to be constructed over an embankment, the depth of exploration should extend up to twice the height of embankment from the ground level. During the soil exploration if the ground water table is struck, the depth from the ground surface is also noted. The types of soils encountered along the route up to the depth under consideration are marked on the soil profile either symbolically or by suitable colour coding.

**Material Survey**

The survey for naturally occurring materials like stone aggregates, soft aggregates, etc. and identification of suitable quarries should be made. Also, availability of manufactured materials like cement, lime, brick, etc. and their locations may be ascertained.

**Traffic Survey**

Traffic surveys conducted in the region form the basis for deciding the number of traffic lanes and roadway width, pavement design and economic analysis of the highway project. Traffic volume counts of the classified vehicles are to be carried out on all the existing roads in the region, preferably for 24 hours per day for seven days. Origin and destination surveys are very useful for deciding the alignment of the roads. This study may be carried out on a suitable sample of vehicle users or drivers. In addition, the required traffic data may also be collected so that the traffic forecast could be made for 10 to 20 year periods.

**Determination of Final Centre Line**

After completing the preliminary surveys and conducting the comparative studies of alternative alignments, the final centre line of the road is to be decided in the office before the final location survey. For this, the preliminary survey maps consisting of contour plans, longitudinal profile and cross sections of the alternate alignments should be prepared and carefully studied to decide the best alignment satisfying engineering aesthetic and economical requirements. After selecting the final alignment, the grade lines are drawn and the geometric elements of the horizontal and vertical alignments of the road are designed.

**Rapid method using aerial survey and modern technique using GPS**

Aerial photographic surveys and photogrammetric methods are very much suited for preliminary surveys, especially when the distance and area to be covered are vast, The survey may be divided into the following steps:

Taking aerial photographs of the strips of land to be surveyed with the required longitudinal and lateral overlaps. Vertical photographs are necessary for the preparation of mosaics.

- a) The photographs are examined under stereoscopes and control points are selected for establishing the traverses of the alternate proposals. The control points are located on the maps
- b) Using stereo-pair observations, the spot levels and subsequently contour details may be noted down on the maps
- c) Photo-interpretation methods are used to assess the geological features, soil conditions, drainage requirements etc.

**Final Location and Detailed Survey**

The alignment finalised at the design office after the preliminary survey is to be first located on the field by establishing the centre line. Next detailed survey should be carried out for collecting the information necessary for the preparation of plans and construction details for the highway project.

**Location**

The centre line of the road finalised in the drawings is to be transferred on the ground during the location survey. This is done using a transit theodolite and by staking of the centre line. The location of the centre line should follow, as closely as practicable, the alignment finalised after the preliminary surveys. Major and minor control points are established on the ground and centre pegs are driven, checking the geometric design requirements. However, modifications in the final location may be made in the field, if found essential. The centre line stakes are driven at suitable intervals, say at 50 metre intervals in plain and rolling terrains and at 20 metre in hilly terrain.

**Detailed Survey**

- Temporary bench marks are fixed at intervals of about 250 m and at all drainage and under pass structures. Levels along the final centre line should be taken at all staked points.
- Levelling work is of great importance as the vertical alignment, earth work calculations



and drainage details are to be worked out from the level notes.

- The cross-section levels are taken up to the desired width, at intervals of 50 to 100 m in plain terrain, 50 to 75 m in rolling terrain, 50 m in built-up areas and 20 m in hilly terrain.
- The cross sections may be taken at closer intervals at horizontal curves and where there is abrupt change in cross slopes.
- All river crossing, valleys etc. should be surveyed in detail up to considerable distances on either side.
- All topographical details are noted down and also plotted using conventional signs. Adequate hydrological details are also collected and recorded.
- A detailed soil survey is carried out to enable drawing of the soil profile. The depth up to which soil sampling is to be done may be 1.5 to 3.0 m below the ground line or finished grade line of the road whichever is lower. However, in case of high embankments, the depth should be up to twice the height of the finished embankment. The spacing of auger borings very much depends upon the soil type and its variations.
- CBR value of soils along the alignment may be determined for designing the pavement.
- The data during the detailed survey should be elaborate and complete for preparing detailed plans, design and estimates of the project.

## **HIGHWAY PROJECTS**

### **General**

In a new highway project, the engineer has to plan, design and construct either a network of new roads or a road link. There are also projects requiring re-design and re-alignment of existing roads of upgrading the geometric design standards.

Once a highway is constructed, development takes place along the adjoining land and subsequent changes in alignment or improvements in geometric standards become very difficult. A badly aligned highway is not only a source of potential traffic hazard, but also causes a considerable increase in transportation cost and strain on the drivers and the passengers. Therefore, proper investigation and planning are most important in a road project, keeping in view the present day needs as well as the future developments of the region.

### **New Highway Project**

The new highway project work may be divided into the following stages:

- a) Selection of route, finalisation of highway alignment and geometric design details
- b) Collection of materials and testing of subgrade soil and other construction materials, mix design of pavement materials and design details of pavement layers
- c) Construction stages including quality control.

### **Route Selection**

The selection of route is made keeping in view the requirements of alignment and the geological, topographical and other features of the locality. However special care should be taken as regards the geometric design standards of the road for possible upgrading of speed standards in future, without being necessary to realign the road. After the alignment is finalised, the plans and working drawings are prepared.

### **Materials and Design**

The soil samples collected from the selected route during the soil surveys are tested in the laboratory in order to design the required pavement thickness and the design of embankment and cut slopes. The basic construction materials such as selected soil, aggregates etc. are collected from the nearest borrow pits and quarries and stacked along the road alignment after subjecting these materials to the specified laboratory tests. In order to design the mixes for the pavement component layers and to specify quality control test values during road construction, mix design tests are carried out in the laboratory.

The possibility of using low-cost construction material like soil-aggregate mixes, soft aggregates, stabilized soil and pozzolonic concrete mixes, in the sub-base or base course layers of pavement should be fully explored. When high quality pavement materials like bituminous mixes or cement concrete are to be used in the surface course, the mix design specification and construction control tests should be strictly followed. The pavement thickness is designed based on anticipated traffic, stability and drainage conditions of the subgrade and the type and thickness of pavement layers chosen for the construction.

In India, the **CBR method** has been recommended by the Indian Roads Congress for designing the thickness of flexible pavements.

**Construction**

The construction of the road may be divided into two stages as follows

- 1) Earth Work
- 2) Pavement Construction.

**Earth Work**

It consists of excavation and construction of the embankments. During the excavation for highway cuts, the earth slopes, their protection and construction of drainage network are taken care of. Highway embankments may be best constructed by rolled-fill method by compacting the soil in layers under controlled moisture and density using suitable rollers. In the case of high embankments, the stability of the embankment foundation and slopes and the possible settlement of the embankment with time are to be investigated.

**Pavement Construction**

It is subsequently taken up starting with the preparation of subgrade and the construction of sub-base, base and surface courses of the pavement.

Steps in a new project work

The various steps in a new highway project may be summarised as given below:

- **Map Study:** This is carried out with the help of available topographic maps of the area
- **Reconnaissance Survey:** During reconnaissance survey, a general idea of a topography and other features, field identification of soils and survey of construction materials, by an on-the spot inspection of the site.
- **Preliminary Survey:** Topographic details and soil survey along alternate alignments, consideration of geometric design and other requirements of alignment, preparation of plans and comparison of alternate routes; economic analysis and selection of final alignment.
- **Location of Final Alignment:** Transfer of the alignment from the drawings to the ground by driving pegs along the centre line of finally chosen alignment, setting out geometric design elements by location of tangent points, apex points, circular and transition curves, elevation of centre line and super elevation details.
- **Detailed Survey:** Survey of the highway construction work or the preparation of longitudinal and cross sections, computations of earth work quantities and other construction material and checking details of geometric design elements.
- **Materials Survey:** Survey of construction materials, their collection and testing.
- **Design:** Design details of embankment and cut slopes, foundation of embankments and bridges, and pavement layers and cross drainage structures.
- **Earth Work:** Excavations for highway cutting and drainage system, construction of embankments.
- **Pavement Construction:** Preparation of subgrade, construction of sub-base, base and surface courses.
- **Construction Controls:** Quality control tests during different stages of construction and check for finished road surface such as unevenness, camber, super elevation and extra widening of pavements at curves.
- **Construction Planning and Programming:** The construction planning and programming to be carried out taking into accounts all the restraints and existing problems. In order to minimise the construction cost and time, it is essential to resort to appropriate approaches such as use of Critical Path Method (CPM) and Project Evaluation and Review Technique (PERT).

## **Re-Alignment Project**

### **Necessity of Re-Alignment**

Most of the present highways in India have been upgraded in stages, from the existing local roads of the pre-automobile era. As these roads were then meant for slow traffic, they are found deficient in the geometric design elements for the present-day automobile traffic. There are several stretches of NH in the country having single lane carriageway, narrow bridges and culverts and many locations with sharp horizontal curves and avoidable zigzags, steep gradients and inadequate sight distances. These defects are to be rectified as early as possible at least in stages, starting with roads of greater importance like NH and SH's. It will be worth-while to adopt more liberal values of geometric design parameters than the ruling minimum values specified, where the conditions are favourable and the costs involved are not excessive. In such cases, it would be possible to upgrade the highway if necessary in future by increasing the width standards only, but without the necessity of re-aligning the road. However, in constrained situations and in difficult terrain, it may not always be economical to improve the existing highway geometries to the recommended design standards. In such cases appropriated speed restrictions have to be imposed to minimise road accidents.

It has been decided as a policy that NH's should as far as possible be able to fully cater to the traffic moving at design speed, fulfilling the comfort and safety requirements, both for the present and future traffic needs. To achieve this objective, it is necessary to plan improvements in the geometries of roads wherever deficient, to the extent economically practicable along with other improvements such as raising of the road above flood water level, pavement resurfacing or construction of overlay for strengthening the pavement structure.

### **Types of Improvement**

The following types of improvement in alignment of existing road may be carried out:

- 1) Improvement of horizontal alignment design elements such as, radius, super elevation, transition curve, providing adequate clearance on inner side of the curve or shifting the curve to provide adequate sight distance, elimination of reverse curve and undesirable zigzags, etc.
- 2) Improvement of vertical alignment design elements like steep gradients, changes in summit curves to increase sight distance, correction of undesirable undulations like humps any dips, etc.

- 3) Raising the level of a portion of a road which is subjected to flooding, submergence or water-logging during monsoons.
- 4) Re-construction of weak and narrow bridges and culverts and changes in waterway at locations slightly away from the existing site.
- 5) Construction of over-bridges or under-bridges at suitable locations across a railway line in place of level crossing or across another road to provide grade separated intersections.
- 6) Re-alignment required due to a portion of the road being submerged under water at the reservoir area on account of construction of a new dam.
- 7) Construction of a bypass to avoid the road running through a town or city
- 8) Defence requirements.

### **General Principles of Re-Alignment**

- While improving the horizontal alignment of roads, improvement in sharp curves and zigzags should be done after considering the whole alignment and not on piece meal basis. The improvement of transition curves would not generally be very costly and therefore such deficiencies should be rectified where-ever necessary. The sight distance available generally gets increased when the horizontal alignment is improved, otherwise the setback distance may be increased at horizontal curves by removing or shifting the obstruction from the inner side of the curve, up to the desired extent,
- While improving the vertical alignment, attempts should be made to provide Overtaking Sight Distance (OSD) at summit curves. On divided highways, the overtaking distance required will be lesser than on un-divided two-way roads, as there is no need to provide for the on-coming vehicles during overtaking operations. However, if it is not possible to provide for OSD, at- least the safe stopping sight distance should be available for the design speed at all locations of the road
- The corrections of minor undulations such as humps and dips may not involve high cost and so it is desirable to provide suitable vertical transition curves for shock-free movement of vehicles travelling at the design speed. Valley curves may be checked for comfort condition and for visibility under the head lights of the vehicles during night driving.
- The road stretches which remain submerged under water even for a short duration of the year or those which are in water-logged areas should be raised before strengthening

or widening pavement section. The formation level be raised such that the subgrade is at least 0.6 m above the HFL. Suitable measures should be adopted against water-logging and care should be taken to provide suitable drainage facilities including the cross drainage works.

- While reconstructing bridges of length greater than 60 m on sites other than the existing ones, separate surveys should be carried out for the selection of suitable sites. The selection of site for major bridges would be governed by the river training works, sub-soil conditions for foundation and hydraulic considerations. However, in small bridges, the road alignment would essentially govern the bridge site selection
- The deciding factor which is being considered for providing over-bridges or under bridges for a NH across railway level crossings is product of number of gate closures and the intensity of traffic on the highway in tonnes per day in the design year. When this product exceeds 50,000 or when the level crossing is within the shunting limits of a railway station, the grade separation is justified. The location is decided keeping in view the highway alignment, the topographic and other site conditions,
- The necessity to provide alternate routes to bypass through traffic is assessed from the origin and destination studies. If the by-passable traffic more than the traffic terminating at the town or built-up area then the bypass may be justified.

### **Steps in The Re-Alignment Project**

- 1) Reconnaissance of the stretch of road to be re-aligned, study of the deficiencies and the possible changes in alignment
- 2) Survey of existing road, recording the topographic features and all other existing features including drainage conditions. The width of the land to be surveyed depends on the amount of shifting anticipated when the road is re-aligned.
- 3) Observations of spot levels along the centre line of the road and cross section levels at suitable intervals. The intervals should be taken at closer intervals at horizontal and vertical curves and near cross drainage works.
- 4) Soil survey along the stretches of land through which the re-aligned road may pass, preparation of typical soil profiles after testing the soil samples in the lab.
- 5) Finalisation of the design features of re-aligned road stretches
- 6) Preparation of drawings and Marking out the centre line of re-aligned road while trying to utilise the existing road to the maximum extent possible.

- 7) Earth-work and preparation of subgrade of the re-alignment road stretches, setting out and construction of new bridges and culverts
- 8) Checking the geometric design elements of the newly aligned stretches of the road
- 9) Design and construction of the new highway pavements

### **Preparation of Drawing for Re-Alignment Project**

The drawings for the re-alignment project should show all the existing features of the road as well as all the proposed improvements.

The following drawings would be needed

- 1) Plan showing existing road, proposed re-alignment, contours and all other features of importance.
- 2) Longitudinal section showing natural ground elevation, surface of the existing road and the grade line for the re-construction
- 3) Cross section showing the existing highway and new roadway drawn at 250m intervals on straights, at the beginning and end of transition curves and at the middle of circular curves. Cross sections are drawn at 50m intervals where the new carriageway falls entirely outside the existing one.



## HIGHWAY GEOMETRIC DESIGN

### INTRODUCTION

The geometric design of highways deals with the dimensions and layout of visible features of the highway such as horizontal and vertical alignments, sight distances and intersections. The designer may be exposed to either plan a new highway network or improve existing highway to meet the requirements of existing and the anticipated traffic.

It is possible to design and construct highway in stages but the geometric elements have to be planned in the initial stages only it will be expensive and difficult to improve it later.

Geometric design of highways deals with following elements

- a) Cross-Section Elements
- b) Sight Distance Consideration,
- c) Horizontal Alignment Details
- d) Vertical Alignment Details
- e) Intersection Elements

### Design Controls and Criteria

Factors affecting the geometric designs are as follows

#### Design Controls and Criteria

The geometric design of highways depends on several design factors. The important factors which control the geometric elements are:

- (a) Design speed
- (b) Topography or terrain
- (c) Traffic factors
- (d) Design hourly volume and capacity
- (e) Environmental and other factors

### Design speed

The design speed is the most important factor controlling the geometric design elements of highways. The design speed is decided taking into account the overall requirements of the highway. In India, different speed standards have been assigned depending upon the importance or the class of the road such as National/State Highways, Major/Other District Roads and Village Roads. Further the design speed standards are modified depending upon the terrain or topography.

**Topography**

The topography or the terrain conditions influence the geometric design of highway significantly. The terrains are classified based on the general slope of the country across the alignment, as plain, rolling, mountainous and steep terrains. The design standards specified for different classes of roads, are different depending on the terrain classification. Further in hilly terrain, it is necessary to allow for steeper gradients and sharper horizontal curves due to the construction problems.

**Traffic Factors**

The factors associated with traffic that affect geometric design of road are the vehicular characteristics and human characteristics of road users. It is difficult to decide the design vehicle or standard traffic lane under mixed traffic flow.

**Environmental and Other Factors**

The environmental factors such as aesthetics, landscaping, air and noise pollution and other local conditions should be given due considerations in the design of road geometrics. Some of the arterial high-speed highways and expressways are designed for higher speed standards and uninterrupted flow of vehicles by providing controlled access and grade separated intersections.

**HIGHWAY CROSS SECTION ELEMENTS**

Pavement Surface depends on the pavement type. The pavement surface type is decided based on the availability of materials and funds, volume and composition of traffic, sub grade, and climatic conditions. The important characteristics of the pavement are

- 1) Friction Considerations
- 2) Unevenness
- 3) Light Reflecting Characteristics
- 4) Drainage of Surface Water

### 1) Friction

The friction of skid resistance between vehicle tyre and pavement surface is one of the factors determining the operating speed and the minimum distance requires for stopping of vehicles.

'Skid' occurs when the wheels slide without revolving or rotating or when the wheels partially revolve i.e., when the path travelled along the road surface is more than the circumferential movements of the wheels due to their rotation. When the brakes are applied, the wheels are locked partially or fully, and if the vehicle moves forward, the longitudinal skidding takes place which may vary, from 0 to 100%.

While a vehicle negotiates a horizontal curve, if the centrifugal force is greater than the counteracting forces (i.e. lateral friction and component of gravity due to super elevation) lateral skidding takes place. The lateral skid is considered dangerous as the vehicle goes out of control leading to an accident. The maximum lateral skid coefficient is generally equal to or slightly higher than the forward skid coefficient in braking tests.

'Slip' occurs when a wheel revolves more than the corresponding longitudinal movement along the roads. Slipping usually occurs in the driving wheel of a vehicle when the vehicle rapidly accelerates from stationary position or from slow speed on pavement surface which is either slippery and wet or when the road surface is loose with mud.

### Factors Affecting Friction or Skid Resistance

The maximum friction offered by pavement surface or the skid resistance depend\* upon the following factors:

Type of pavement surface namely, cement concrete, bituminous, WBM. earth surface etc.

- Macro-texture of the pavement surface or its relative roughness
- Condition of pavement namely
- Type and condition of tyre
- Speed of vehicle
- Extent of brake application or brake efficiency
- Load and tyre pressure
- Temperature of tyre and pavement

For the calculation purposes, the IRC has recommended the longitudinal friction coefficient values of 0.35 to 0.40 and lateral coefficient values of 0.15. for expressways and NH's with design speed of 120 and 100kmph it is 0.10 and 0.11

## 2) Pavement Unevenness

The longitudinal profile of the road pavement has to be even' in order to provide a good riding comfort to fast moving vehicles and to minimise the VOC. Presence of undulations on the pavement surface is called pavement unevenness which results in

- Increase in Discomfort and Fatigue to Road Users
- Increase in Fuel Consumption and Tyre Wear and Increase in VOC
- Reduction in Vehicle Operating Speed and Increase in Accident Rate

The pavement surface should therefore be maintained with minimum possible unevenness or undulations so that the desired speed can be maintained in conformity with other geometric standards. Loose road surface increases the resistance to traction and causes increase in fuel consumption.

The unevenness of pavement surface is commonly measured by using a simple equipment called '**Bump Integrator**' (**BI**), in terms of **Unevenness Index** which is the cumulative measure of vertical undulations of the pavement surface recorded per unit length of the road. Internationally, the riding quality of a pavement surface is quantified in terms of 'roughness' and is expressed as International Roughness Index (IRI) in units of m/km. The relation between the unevenness measured using bump integrator in mm/km and the International Roughness index in m/km is as follows

$$\mathbf{BI = 630 (IRI)^{1.12}}$$

Undulations of newly laid pavement surface are sometimes measured using a straight edge and wedge scale, in terms of the depth and number of depressions or ruts along and across the pavement. It may be mentioned here that there are several advanced techniques and equipment available now to evaluate the pavement surface condition.

## 3) Light Reflecting Characteristics

Night visibility depends upon the colour and light reflecting characteristics of the pavement surface. The glare caused by the reflection of head lights is considerably high on wet pavement surface than on the dry pavement.

- Light coloured or white pavement surface give good visibility at night particularly during rains: however white or light colour of pavement surface may produce glare and eye strain during bright sunlight.
- Black top pavement surface on the other hand provides very poor visibility at nights, especially when the surface is wet.

**Cross Slope or Camber**

Cross slope or camber is the slope provided to the road surface in the transverse direction to drain off the rain water from the road surface. Drainage and quick disposal of water from the pavement surface by providing cross slope is considered important because of the following reasons:

- 1) To prevent the entry of surface water into the pavement layers and the subgrade soil through pavement.
- 2) To prevent the entry of water into the bituminous pavement layers, as continued contact with water causes stripping of bitumen from the aggregates and results in deterioration of the pavement layer
- 3) To remove the rain water from the pavement surface as quickly as possible and to allow the pavement to get dry soon after the rain.

The rate of camber or cross slope is usually designated by 1 in 'n' which means the transverse slope is in ratio 1 vertical to n horizontal.

The required camber of a pavement depends on

- a) Type of pavement surface
- b) The amount of rainfall

It is desirable not to provide excessive camber or steep cross slope on road pavements. Only the minimum camber needed to drain off surface water may be adopted keeping in view the type of pavement surface and the amount of rainfall in the locality. Too steep cross slope is not desirable because of the following reasons:

- Transverse tilt of vehicles causes uncomfortable side thrust and a drag on the steering wheel of automobiles. Also, the thrust on the wheels along the pavement edges is more causing unequal wear of the tyres as well as road surface
- Discomfort causing throw of vehicle when crossing the crown during overtaking operations.
- Problems of possible toppling over of highly laden bullock carts and trucks
- Formation of cross ruts due to rapid flow of water
- Tendency of most of the vehicles to travel along the centre line

### Recommended values of camber

The values of camber recommended by the IRC for different types of road surfaces are given in the below table.

**Recommended values of camber for different types of road surfaces**

Sl. No.	Type of road surface	Range of camber in areas of	
		Heavy rainfall	Low rainfall
1.	Cement concrete and high type bituminous surface	1 in 50 or 2.0 %	1 in 60 or 1.7%
2.	Thin bituminous surface	1 in 40 or 2.5 %	1 in 50 or 2.0 %
3.	Water bound Macadam and gravel pavement	1 in 33 or 3.0 %	1 in 40 or 2.5%
4.	Earth road	1 in 25 or 4.0 %	1 in 33 or 3.0 %

The cross slope for shoulders should be 0.5% steeper than the cross slope of adjoining pavement, subject to a minimum of 3.0% and a maximum value of 5.0% for earth shoulders. The cross slope suggested for the carriageway, paved shoulders and edge strip of expressways with bituminous surface as well as cement concrete surface is 2.5 % in regions with annual rain fall exceeding 1000 mm and 2.0 % in places with less than 1000 mm rain fall.

### SHAPE OF CROSS SLOPE

In the field, camber of the pavement cross section is provided with a suitable shape. Different shapes that are commonly adopted are

- 1) Parabolic
- 2) Straight Line
- 3) Straights with parabolic curve

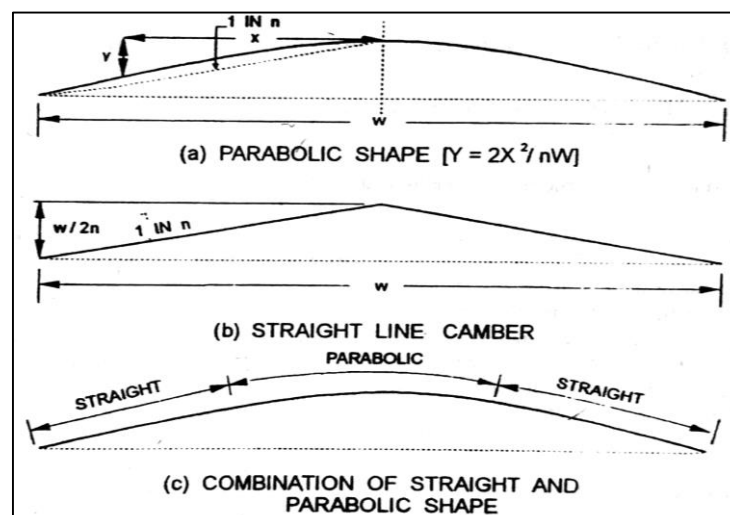

**Providing Camber in the field**

In order to provide the desired amount and shape of camber, templates or camber boards are prepared with the chosen shape and specified cross slope and they can be used to check the lateral profile of finished pavements.

**a) Parabolic Camber**

$$y = x^2/a$$

where  $a = nW/2$

**b) Straight Line Camber**

$$y = W/2n$$

W – width, n – cross slope in 1 in n

**WIDTH OF PAVEMENT OR CARRIAGEWAY**

The width of pavement or carriageway depends on

- 1) Width of Traffic Lane
- 2) Number of Lanes.

The portion of carriageway width that is intended for one line of traffic movement is called a traffic lane. As different classes of vehicles travel along the same roadway generally the lane width is decided based on a standard vehicle such as the passenger car. However, it is also necessary to consider the maximum width of the largest vehicle class such as the heavy commercial vehicle (HCV) which is legally permitted to use the roadway in the country.

**Width of carriageway recommended by IRC**

<b>Class of Road</b>	<b>Width of Carriageway, m</b>
Single Lane Road	3.75
Two Lane Road, without raised kerbs	7.0
Two Lane Road, with raised kerbs	7.5
Intermediate Carriageway	5.5
Multi Lane Pavements	3.5 per lane

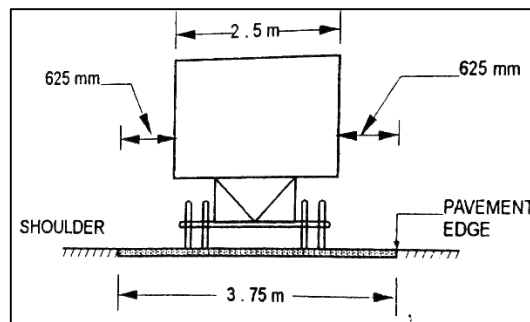

Single Lane Pavement

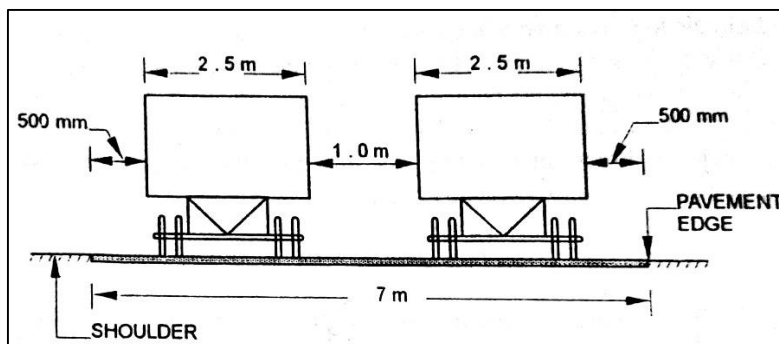

Two Lane Pavement

## MEDIANS/TRAFFIC SEPARATORS

In highways with divided carriageway, a median is provided between two sets of traffic lanes intended to divide the traffic moving in opposite directions. The main function of the median is to prevent head-on collision between vehicles moving in opposite directions on adjacent lanes. The median is also called or traffic separator. The traffic separators used may be in the form of pavement markings, physical dividers or area separators. Pavement marking is the simplest of all these, but this will not rule out head-on collision. The mechanical separator may be suitably designed keeping in view safety considerations.

## KERBS

Kerb indicates the boundary between the pavement and median or foot path or island or shoulder. It is desirable to provide kerbs on urban roads. Refer Fig. There are a variety of kerb designs. Kerbs may be mainly divided based on their functions.

### a) Low or Mountable Kerbs

These types of kerbs are provided such that they encourage the traffic to remain in the through traffic lanes and also allow the driver to enter the shoulder area with little difficulty.



**b) Semi-Barrier Type Kerbs**

When the pedestrian traffic is high, these kerbs are provided. Their height is 15 cm above the pavement edge.

**c) Barrier Type Kerbs**

They are designed to discourage vehicles from leaving the pavement. They are provided when there is considerable amount of pedestrian traffic. They are placed at a height of 20 cm above The Pavement Edge with A Steep Batter.

**d) Submerged Kerbs**

They are used in rural roads. The kerbs are provided at pavement edges between pavement edge and shoulder

**ROAD MARGINS**

The portion of the road beyond the carriageway and on the roadway can be generally called road margin. Various elements that form the road margins are given below.

**Shoulders**

Shoulders are provided on both sides of the pavement all along the road in the case of undivided highway and are provided on the outer edge of the highway in divided carriage way

The important functions of shoulders are:

- (a) Shoulders provide structural stability and support to the edges of the flexible pavements.
- (b) The capacity of the carriageway and the operating speeds of vehicles increase if the shoulders are laid and maintained in good condition.
- (c) Shoulders serve as emergency lanes for vehicle compelled to be taken out of the main carriageway or roadway. Shoulders should have sufficient load bearing capacity to support loaded truck even in wet weather
- (d) Shoulders also act as service lanes for vehicles that are disabled. The width of shoulder should be adequate to accommodate stationary vehicle fairly away from the edge of adjacent lane.

**Guard rails**

Guard rails are provided at the edge of the shoulder when the road is constructed on a fill so that vehicles are prevented from running off the embankment, especially when the height of the fill exceeds 3 m. Guard stones (painted with black and white strips) are installed

at suitable intervals along the outer edge of the formation at horizontal curves of roads running on embankments along rural areas so as to provide better night visibility of the curves under head lights of vehicles

### **Footpath or side-walk**

In order to provide safe facility to pedestrians to walk along the roadway, foot paths or side-walks are provided in urban areas where the pedestrian traffic is noteworthy and the vehicular traffic is also heavy. By providing good foot path facility, the pedestrians can keep off from the carriageway and they are segregated from the moving vehicular traffic. Thus, the operating speeds of the vehicular traffic increases and there will be marked reduction in accidents involving pedestrians.

### **Drive ways**

Drive ways connect the highway with commercial establishment like fuel-stations, service-stations etc. Drive ways should be properly designed and located, fairly away from an intersection. The radius of the drive way curve should be kept as large as possible, but the width of the drive way should be minimised to reduce the crossing distance for the pedestrians.

### **Cycle tracks**

Cycle tracks are provided in urban areas where the volume of cycle traffic on the road is very high. A minimum width of 2 m is provided for the cycle track and the width may be increased by 1.0 m for each additional cycle lane.

### **Parking lanes**

Parking lanes are provided on urban roads to allow kerb parking. As far as possible only 'parallel parking' should be allowed as it is safer for moving vehicles. For parallel parking, the minimum lane width should be 3.0 m.

### **Bus bays**

Bus bays may be provided by recessing the kerb to avoid conflict with moving traffic. Bus bays should be located at least 75 m away from the intersections.

### **Lay-byes**

Lay-byes are provided near public conveniences with guide maps to enable drivers to stop clear off the carriageway. Lay-byes should normally be of 3.0 width and at least 30 m length with 15 m end tapers on both sides.

**Frontage roads**

Frontage roads are provided to give access to properties along an important highway with controlled access to express way or freeway. The frontage roads may run parallel to the highway and are isolated by a separator, with approaches to the through facility only at selected points, preferably with grade separation.

**WIDTH OF FORMATION OR ROADWAY**

Width of formation or roadway is the sum of widths of pavement or carriageway including separators, if any and the shoulders. Formation or roadway width is the top width of the highway embankment or the bottom width of highway cutting excluding the side drains.

**RIGHT OF WAY AND LAND WIDTH**

Right of way is the area of land acquired for the road, along its alignment. The width of the acquired land for right of way is known as 'land width' and it depends on the importance of the road and possible future development. A minimum land width has been prescribed for each category of road. A desirable range of land width has also been suggested for each category of road. While acquiring land for a highway it is desirable to acquire more width of land as the cost of adjoining land invariably increases as soon as the new highway is constructed.

## SIGHT DISTANCE

### Sight Distance and Importance

Sight distance is the length of road visible ahead of the driver at any instance. Sight distance available at any location of the carriageway is the actual distance a driver with his eye level at a specified height above the pavement surface has visibility of any stationary or moving object of specified height which is on the carriageway ahead. The sight distance between the driver and the object is measured along the road surface.

### Restrictions to Sight Distance

Restrictions to visibility or sight distance may be caused in the following circumstances

- At horizontal curves, when the line of sight is obstructed by objects at the inner side of the curve. Here the sight distance is measured along the centre line of the horizontal curve when the vehicle driver is able to see another vehicle or object on the carriageway
- At a vertical curve, the line of sight is obstructed by the road surface of the summit curve (i.e., a vertical curve of the road with convexity upwards)
- In this case also the sight distance is measured along the centre line of the vertical curve when the vehicle driver is able to see another vehicle or object on the road
- At an uncontrolled intersection when a driver from one of the approach roads is able to sight a vehicle from another approach road proceeding towards the intersection, Here the sight distance for each vehicle driver is the distance from the position when the two can see each other up to the intersection point of the two roads.

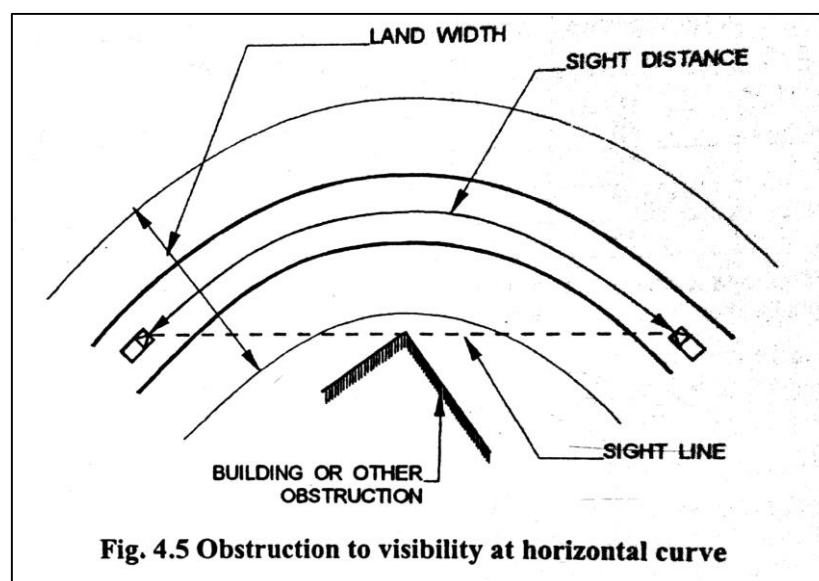

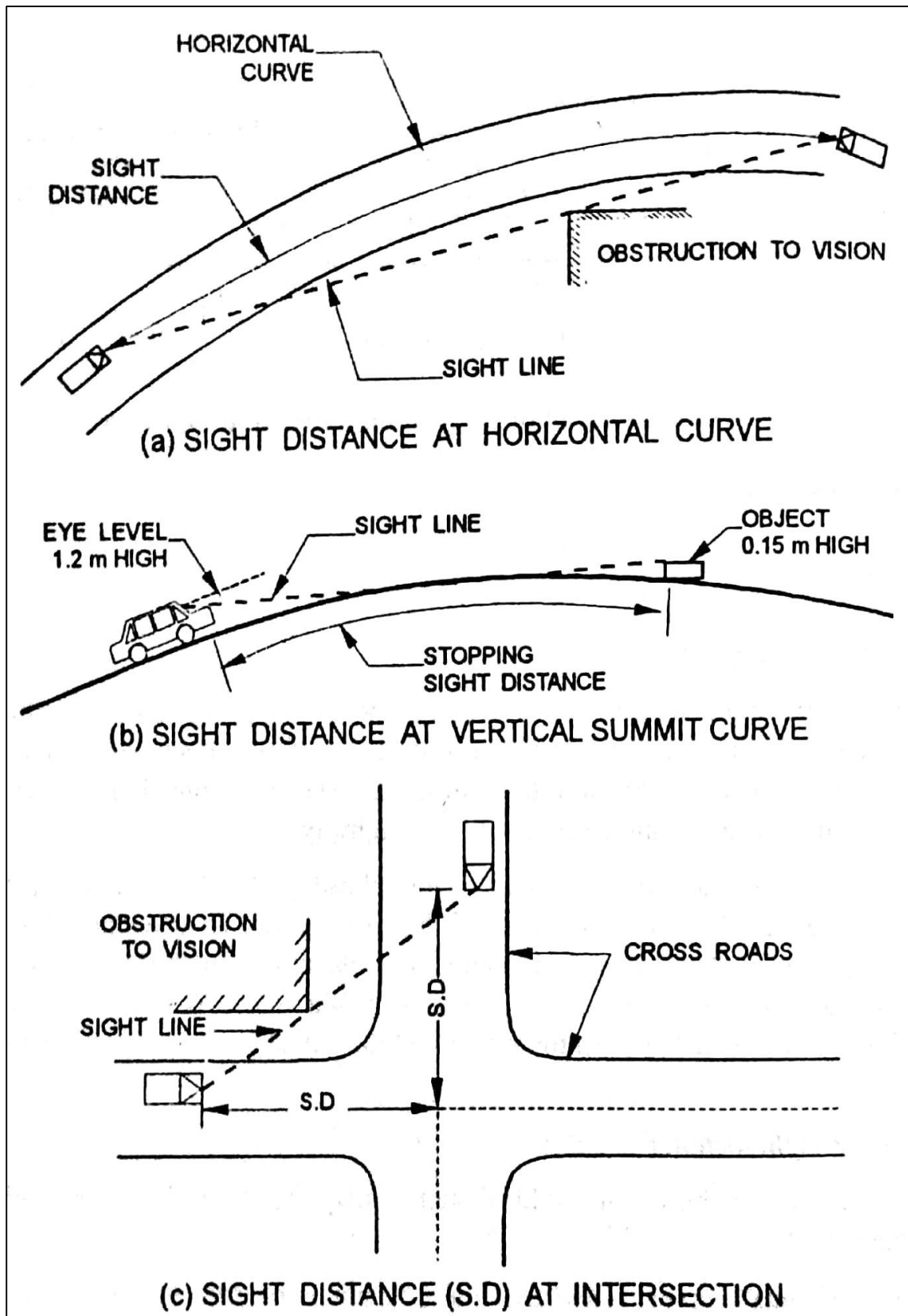

## **TYPES OF SIGHT DISTANCE**

Sight distance required by drivers applies to geometric designs of highways and for traffic control. Three types of sight distances are considered in the design

- a) **Stopping Sight Distance (SSD)** or absolute minimum sight distance
- b) **Safe Overtaking Sight Distance (OSD)** or Passing Sight Distance
- c) **Safe Sight Distance** for entering into uncontrolled intersections.

Apart from the three situations mentioned above, the following sight distances are considered by the IRC in highway design

- d) **Intermediate Sight Distance**
- e) **Head Light Sight Distance**

## **STOPPING SIGHT DISTANCE (SSD)**

### **Factors on which visibility or sight distance depends**

The minimum distance visible to a driver ahead or the sight distance available on a highway at any spot should be of sufficient length to safely stop a vehicle travelling at design speed, without collision with any other obstruction. Therefore, this Stopping Sight Distance (SSD) is also called Absolute Minimum Sight Distance. This is also sometimes called Non-Passing Sight Distance.

The sight distance available to a driver travelling on a road at any instance depends on the following factors:

- a) Features of the road ahead
- b) Height of the driver's eye above the road surface
- c) Height of the object above the road surface

IRC has suggested the height of eye level of driver as 1.2 m and the height of the object as 0.15 m above the road surface.

### **Factors on which stopping distance depends**

The distance within which a motor vehicle can be stopped depends upon the factors listed below

- a) Total reaction time of the driver
- b) Speed of vehicle
- c) Efficiency of Brakes
- d) Frictional Resistance between the road and the tyre

- e) Gradient of the road, if any

### TOTAL REACTION TIME OF DRIVER

Reaction time of the driver is the time taken from the instant the object is visible to the driver to the instant the brakes are effectively applied. The actual time gap or the reaction time of the driver depends on several factors. During this period of time the vehicle travels a certain distance at the original speed, which may be assumed to be the design speed of the road. Thus, the stopping distance increases with increase reaction time of the driver.

The total reaction time ( $t$ ) may be split up into two parts

#### Perception Time

It is the time required for a driver to realise that brakes must be applied. It is the time from the instant the object comes on the line of sight of the driver to the instant he realises that the vehicle needs to be stopped. The perception time varies from driver to driver and also depends on several other factors such as the distance of object and other environmental conditions.

#### Brake Reaction Time

It is also depending on several factors including the skill of the driver, the type of the problems and various other environmental factors.

The total reaction time may be explained with the help of PIEV theory.

#### PIEV THEORY

According to PIEV theory, the total reaction time of the driver is split into four parts, viz., time taken by the driver for

- 1) Perception
- 2) Intellection
- 3) Emotion
- 4) Volition

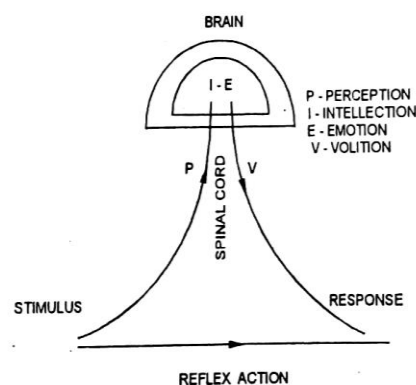

The PIEV time of a driver also depends on several factors such as physical and psychological characteristics of the driver, type of the problem involved, environmental conditions and temporary factors.

### **Speed of vehicle**

The stopping distance depends very much on the speed of the vehicle. First, during the total reaction time of the driver the distance moved by the vehicle will depend on the speed. Second, the braking distance or the distance moved by the vehicle after applying the brakes, before coming to a stop depends also on the initial speed of the vehicle.

### **Efficiency of brakes**

The braking efficiency is said to be 100 percent if the wheels are fully locked preventing them from rotating on application of the brakes. This will result in 100 percent skidding which is normally undesirable, except in utmost emergency. Also skidding is considered to be dangerous, as it is not possible for the driver to easily control a vehicle after it starts skidding.

### **Frictional resistance between road and tyres**

The frictional resistance developed between road and tyres depends upon the 'skid resistance' or the coefficient of friction,  $f$  between the road surface and the tyres of the vehicle.

### **Analysis of Stopping Distance**

The stopping distance of a vehicle is the sum of

- a) The distance travelled by the vehicle at uniform speed during the total reaction time,  $t$  which is known as **LAG DISTANCE**.
- b) The distance travelled by the vehicle after the applications of the brakes, until the vehicle comes to a dead stop which is known as **BRAKING DISTANCE**.

### **LAG DISTANCE**

During the total reaction time,  $t$  seconds the vehicle may be assumed to move forward with a uniform speed at which the vehicle has been moving and this speed may be taken as the design speed. If ' $v$ ' is the design speed in m/sec and ' $t$ ' is the total reaction time of the driver in seconds, then

$$\text{Lag Distance} = v t$$

$$\text{If the design speed is } V \text{ kmph, then the lag distance} = V t \times \frac{1000}{60 \times 60}$$

$$= 0.278 V t \approx \mathbf{0.28 V t} \text{ in meters}$$



IRC has recommended the value of reaction time  $t$  as 2.5 sec for calculation of Stopping Distance

### BRAKING DISTANCE ON LEVEL SURFACE

The coefficient of friction  $f$  depends on several factors such as the type and condition of the pavement and the value of  $f$  decreases with the increase in speed. IRC has recommended a set of friction coefficient values for the determination of stopping sight distance.

Speed, kmph	20 – 30	40	50	60	65	80	100 and above
Longitudinal friction coefficient value, $f$ for SSD	0.40	0.38	0.37	0.36	0.36	0.35	0.35

The braking distance,  $l = \frac{v^2}{2gf}$

Where  $l$  - braking distance, m

$v$  - speed of the vehicle, m/sec

$f$  - design coefficient of friction,  $f$  (0.40 to 0.35)

$g$  - acceleration due to gravity – 9.8 m/sec<sup>2</sup>

### STOPPING DISTANCE ON LEVEL ROAD

Stopping Distance,  $SD = \text{Lag Distance} + \text{Braking Distance}$

$$SD = v t + \frac{v^2}{2gf} \text{ in meters}$$

If speed is  $V$  kmph, stopping distance

$$SD = 0.278 V t + \frac{v^2}{254f} \text{ in meters}$$

### STOPPING DISTANCE AT SLOPES

$$SD = \left[ v t + \frac{v^2}{2g(f \pm 0.01n)} \right] \text{ in meters}$$

If speed is  $V$  kmph, stopping distance

$$SD = 0.278 V t + \frac{v^2}{254(f \pm 0.01n)} \text{ in meters}$$

IRC has recommended the SSD values for different speed as follows

Design Speed, kmph	20	25	30	40	50	60	65	80	100
SSD for design, m	20	25	30	45	60	80	90	120	180

**PROBLEMS****OVERTAKING SIGHT DISTANCE (OSD)****Over Taking Requirement**

If all the vehicles travel along a road at the design speed, then theoretically there should be no need for any overtaking. In fact, all vehicles do not move at the design speed as each driver is free to travel at lower speeds and this is particularly true under **Mixed Traffic** conditions. It is necessary for fast moving vehicle to overtake or pass the slow-moving traffic.

The minimum distance open to the vision of the driver of a vehicle intending to overtake slow vehicle ahead with safety against the traffic of opposite direction is known as **Minimum Overtaking Sight Distance (OSD)** or **Safe Passing Sight Distance**

The OSD is the distance measured along the centre line of the road which a driver with his eye level at 1.2m above the road surface can see the top of an object 1.2m above the road surface

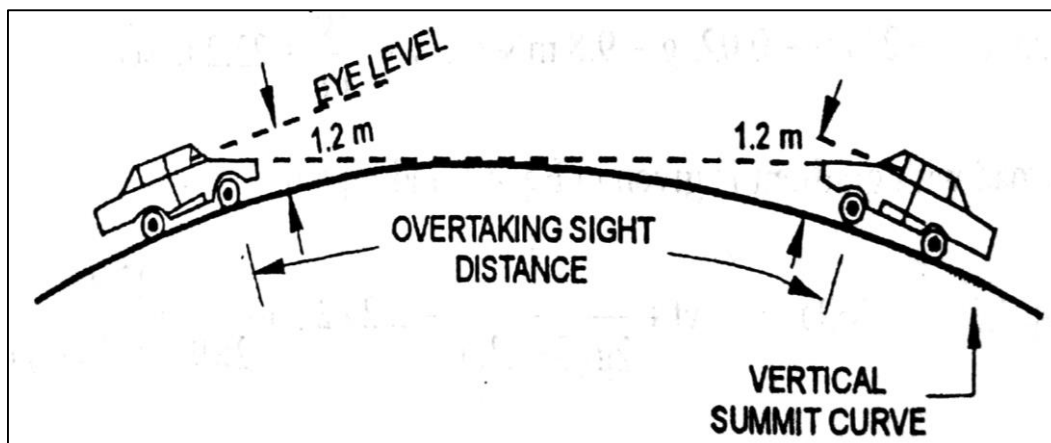

Measurement of OSD

**Factor Affecting OSD**

- Speeds of
  - 1) Overtaking Vehicle
  - 2) Overtaken Vehicle
  - 3) Vehicle coming from opposite direction
- Distance between the overtaking and overtaken vehicles, the minimum spacing between vehicles depends on the speeds
- Skill and reaction time of the driver
- Rate of acceleration of overtaking vehicle

- Gradient of the road

## ANALYSIS OF OSD ON A 2 – WAY ROAD

### Simple overtaking process on a 2 – lane highway with 2 – way traffic movement

Vehicle A travelling at the design speed  $v$  m/sec or  $V$  kmph desires to overtake another slow-moving vehicle B moving at a speed of  $v_b$  m/sec or  $V_b$  kmph. The vehicle A has to accelerate, shift to the adjacent right-side lane, complete the overtaking manoeuvre and return to the left lane, before oncoming vehicle C approaches the overtaking stretch.

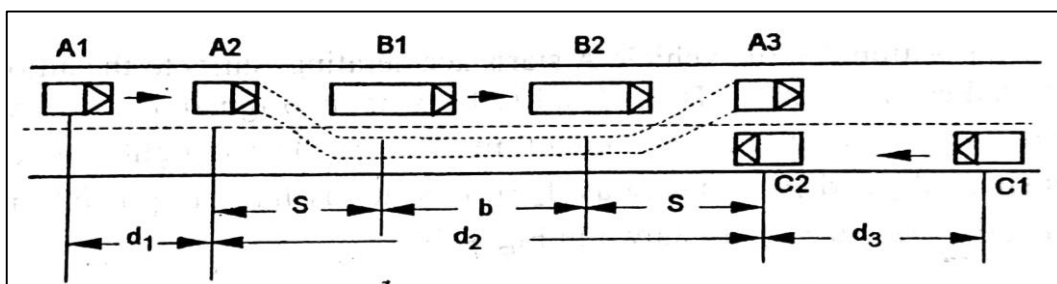

The overtaking manoeuvre may be split up into 3 operations, thus dividing OSD into 3 parts  $d_1$ ,  $d_2$  and  $d_3$ .

- $d_1$  is the distance (m) travelled by the overtaking vehicle A during the reaction time,  $t$  (secs) of the driver from position A1 to A2 before starting to overtake the slow vehicle B
- $d_2$  is the distance travelled (m) travelled by the vehicle A during the actual overtaking operation during  $T$  (secs) from position A2 to A3
- $d_3$  is the distance (m) travelled by oncoming vehicle C during the actual overtaking operation of A during  $T$  (secs) from position C1 to C2.

Thus, on a 2-lane road with 2-way traffic the OSD =  $d_1 + d_2 + d_3$  in meters

### Assumptions made in the analysis

Assumptions made to calculate the values of  $d_1$ ,  $d_2$  and  $d_3$  (m) are given below:

- The overtaking vehicle A is forced to reduce its speed from the design speed  $v$  (m/sec) to  $V_b$  (m/sec) of the slow vehicle B and move behind it, allowing a space  $s$  (m), till there is an opportunity for safe overtaking operation
- When the driver of vehicle A finds sufficient clear gap ahead, decides within a reaction time  $t$  (sec) to accelerate and overtake the vehicle B, during which the vehicle A moves at speed  $v_b$  (m/sec) through a distance  $d_1$  from position A1 to A2.

- The vehicle A accelerates and overtakes the slow vehicle B within a distance  $d_2$  during the overtaking time,  $T$  (sec) between the position  $A_2$  to  $A_3$
- The distance  $d_2$  is split up into three parts
  - a) Spacing,  $s$  (m) between  $A_2$  and B
  - b) Distance  $b$  (m) travelled by the slow vehicle B between  $B_1$  and  $B_2$  during the overtaking manoeuvre of A
  - c) Spacing (m) between  $B_2$  and  $A_3$
- During this overtaking time  $T$  (sec), the vehicle C coming from opposite direction travels through a distance  $d_3$  from position  $C_1$  to  $C_2$

### Determination of the components of OSD

- a) From position  $A_1$  to  $A_2$ , the distance,  $d_1$  (m) travelled by overtaking vehicle A, at the reduced speed  $v_b$  (m/sec) during the reaction time,  $t$  (sec) =  $v_b t$  (m). The IRC suggests that this reaction time  $Y$  of the driver may be taken as 2.0 sec as an average value, as the aim of the driver is only to find an opportunity to overtake. Therefore

$$d_1 = 2v_b$$

- b) From position  $A_2$ , the vehicle A starts accelerating, shifts to the adjoining lane, overtakes the vehicle B, and shifts back to its original lane ahead of B in position  $A_3$  during the overtaking time,  $T$  (sec). The straight distance between position  $A_2$  and  $A_3$  is taken as  $d_2$  (m), which is further split into three parts, viz.,

$$d_2 = (s + b + s)$$

- c) The minimum distance between position  $A_2$  and  $B_1$  may be taken as the minimum spacing  $s$  (m) between the two vehicles while moving with the speed  $v_b$  (m/sec). The minimum spacing between vehicles depends on their speed and is given by empirical formula

$$s = (0.7 v_b + 6)$$

- d) Now the time  $T$  depends on speed of overtaken vehicle B and the average acceleration  $a$  (m/sec<sup>2</sup>) of overtaking vehicle A. The overtaking time  $T$  (sec) may be calculated by equating the distance  $d_2$  to  $(v_b T + \frac{1}{2} a T^2)$  using the general formula for the distance travelled by a uniformly accelerating body with initial speed  $v_b$  m/sec and  $a$  is the average acceleration during overtaking in m/sec<sup>2</sup>

$$d_2 = (v_b T + 2s)$$

- e) The distance travelled by vehicle C moving at design speed  $v$  (m/sec) during the

overtaking operation of vehicle A i.e. during time T (sec) is the distance  $d_2$  (m) between positions  $C_1$  to  $C_2$ . Hence,

$$d_3 = v T \text{ (m)}$$

In m/sec units

$$\text{OSD} = (d_1 + d_2 + d_3) = (v_b t + v_b T + 2s + vT)$$

Here

$v_b$  = initial speed of overtaking vehicle, m/s

$t$  = reaction time of driver = 2 sec

$V$  = speed of overtaking vehicle or design speed, kmph

$$T = \sqrt{\frac{4 s}{a}}$$

$s$  = spacing of vehicles =  $(0.7 v_b + 6)$

$a$  = average acceleration during overtaking, m/sec.

In kmph units

$$\text{OSD} = 0.28 V_b t + 0.28 V_b T + 2s + 0.28 V T$$

Here

$V_b$  = initial speed of overtaking vehicle, kmph

$t$  = reaction time of driver = 2 sec

$V$  = speed of overtaking vehicle or design speed, kmph

$$T = \sqrt{\frac{4 \times 3.6 s}{A}} = \sqrt{\frac{14.4 s}{A}}$$

$s$  = spacing of vehicles =  $(0.2 V_b + 6)$

$A$  = average acceleration during overtaking, kmph

In case the speed of overtaken vehicle ( $v_b$  or  $V_b$ ) is not given, the same may be assumed as 4.5 m/sec or 16 kmph less than the design speed of the highway. Therefore,

$$v_b = (v - 4.5) \text{ m/sec}$$

$$V_b = (V - 16) \text{ kmph}$$

where  $v$  is the design speed in m/sec

$V$  is the design speed in kmph.

The acceleration of the overtaking vehicle varies depending on several factors such as the make and model of the vehicle, its condition, load and the speed; actual acceleration also depends on

the characteristics of the driver. The average rate of acceleration during overtaking manoeuvre may be taken corresponding to the design speed.

Maximum overtaking acceleration at different speeds

Speed		Maximum overtaking acceleration	
V, kmph	v, m/sec	A, kmph/sec	a, m/sec
25	6.93	5.00	1.41
30	8.34	4.80	1.30
40	11.10	4.45	1.24
50	13.86	4.00	1.11
65	18.00	3.28	0.92
80	22.20	2.56	0.72
100	27.80	1.92	0.53

Overtaking sight distance on two-lane highways for different speeds

Speed kmph	Time component, seconds			Safe overtaking sight distance (OSD), m
	For overtaking manoeuvre	For opposing vehicle	Total	
40	9.0	6.0	15	165
50	10.0	7.0	17	235
60	10.8	7.2	18	300
65	11.5	7.5	19	340
80	12.5	8.5	21	470
100	14.0	9.0	23	640

## CRITERIA FOR SIGHT DISTANCE REQUIREMENT ON HIGHWAY

### Absolute Minimum Sight Distance

SSD for the design speed is the absolute minimum sight distance and this should be made available all along the road stretch irrespective of the category of road. If on any road stretch

SSD is not available due to any reason such as obstruction to vision, immediate steps should be taken to either remove the obstruction to the sight line or install suitable regulatory signs to specify the speed limit along with appropriate warning signs.

### Overtaking Sight Distance

It is desirable that adequate overtaking sight distance is available on most of the road stretches such that the vehicles travelling at the design speed can overtake slow vehicles at the earliest opportunity.

- On road stretches with two-way traffic movement, the minimum overtaking distance should be  $(d_1 + d_2 + d_3)$  where overtaking is not prohibited.
- On divided highways and on roads with one way traffic regulation, the overtaking distance need be only  $(d_1 + d_2)$  as no vehicle is expected from the opposite direction.
- On divided highways with four or more lanes, it is not essential to provide the usual OSD; however, the sight distance on any highway should be more than the SSD, which is the absolute minimum sight distance.

### Overtaking Zones

It is desirable to construct highways in such a way that the length of road visible ahead at every point is sufficient for safe overtaking. This is seldom practicable and there may be stretches where the safe overtaking distance cannot be provided. In such zones where overtaking or passing is not safe or is not possible, sign posts should be installed indicating **No Passing** or **Overtaking Prohibited** before such restricted zones start. However overtaking opportunity for vehicles moving at design speed should be given at as frequent intervals as possible. These zones which are meant for overtaking are called **Overtaking Zones**.

The width of carriageway and the length of overtaking zone should sufficient for safe overtaking. Sign posts should be installed at sufficient distance in advance to indicate the start of the overtaking zones, this distance may be equal to

- $(d_1 + d_2)$  for one-way roads
- $(d_1 + d_2 + d_3)$  for two-way roads

**The minimum length of overtaking zone = 3 (OSD)**

**The desirable length of overtaking zones = 5 (OSD)**

## INTERMEDIATE SIGHT DISTANCE

At stretches of the road where requires OSD cannot be provided, as far as possible intermediate Sight Distance  $ISD$  equal to twice  $SSD$  may be provided. The measurement of the  $ISD$  may be made assuming both the height of the eye level of the driver and the object to be 1.2 metres above the road surface. Therefore

$$ISD = 2 SSD$$

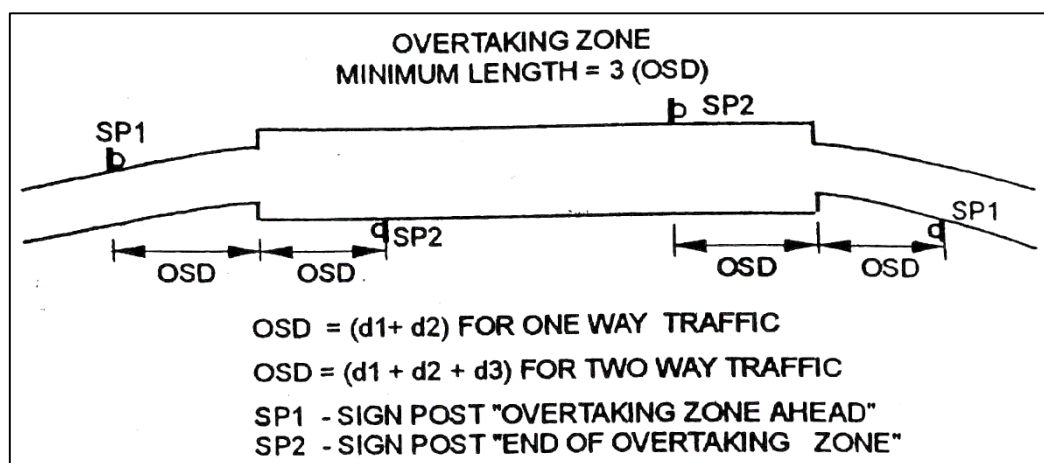

## Sight Distance at Uncontrolled Intersections

It is important that on all approaches of intersecting roads, there is a clear view across the corners from a sufficient distance so as to avoid collision of vehicles. This is all the more important at uncontrolled intersections. The sight line is obstructed by structures or other objects at the corners of the intersections. The area of unobstructed sight formed by the lines of vision is called the sight triangle.

The design of sight distance at intersections may be based on three possible conditions,

- a) Enabling the approaching vehicle to change speed
- b) Enabling approaching vehicle to stop
- c) Enabling stopped vehicle to cross a main road
- d) Enabling the approaching vehicle to change speed



## DESIGN OF HORIZONTAL ALIGNMENT

### General

Often changes in the direction are necessitated in highway alignment due to various reasons such as topographic considerations, obligatory points. The geometric design elements pertaining to horizontal alignment of highway should consider safe and comfortable movement of vehicles at the designated design speed of the highway. It is therefore necessary to avoid sudden changes in direction with sharp curves or reverse curves which could not be safely and conveniently negotiated by the vehicles at design speed. Improper design of horizontal alignment of roads would necessitate speed changes resulting in higher accident rate and increase in vehicle operation cost.

Various design elements to be considered in the horizontal alignment are design speed, radius of circular curve, type and length of transition curves, super elevation, widening of pavement on curves and required set-back distance for fulfilling sight distance requirements.

### Design Speed

The design speed is the main factor on which geometric design elements depend. In other words, the geometric details of a highway mainly depend on the design speed. All the important geometric elements such as sight distances, radius of horizontal curve, length of horizontal transition curve, rate of super elevation, extra widening of pavement at horizontal curve, length of summit and valley curves are dependent on the design speed.

The design speed of roads depends upon

- 1) Class of the Road
- 2) Terrain

The speed standards of a particular class of road thus depend on the classification of terrain through which it passes. The terrains have been classified as plain, mountainous and steep, depending on the cross slope of the country as given in table below

Terrain classification	Cross slope of the country, percent
Plain	0-10
Rolling	10-25
Mountainous	25-60
Steep	greater than 60

Two values of design speeds are considered at the design stage of highway geometries namely,

- 1) Ruling design speed
- 2) Minimum design speed

As a general rule, attempt should be made to design all the geometric element of the highway for the 'ruling design speed'. This is because ruling design speeds are guiding criteria for the geometric design. However, 'minimum design speed' may be accepted where site conditions or economic considerations warrant.

The ruling design speeds suggested for the National and State Highways in India passing through plain terrain is 100 kmph and through rolling terrain is 80kmph and minimum design speed values standardized by the IRC for of roads on different terrains in rural (non-urban) areas are given in Table below

Road Classification	Design Speed in kmph							
	Plain		Rolling		Mountainous		Steep	
	Ruling	Min.	Ruling	Min.	Ruling	Min.	Ruling	Min.
Expressway	120	100	100	80	80	60	80	60
NH and SH	100	80	80	65	50	40	40	30
MDR	80	65	65	50	40	30	30	20
ODR	65	50	50	40	30	25	25	20
VR	50	40	40	35	25	20	25	20

The recommended design speeds for different classes of urban roads

- 1) Arterial Roads: 80 Kmph
- 2) Sub-Arterial Roads: 60 Kmph
- 3) Collector Streets: 50 Kmph
- 4) Local Streets: 30 Kmph

### Horizontal Curves

A horizontal highway curve is a curve in plan to provide change in direction to the centre line of a road. A simple circular curve may be designated by either the radius,  $R$  of the curve in meters or the degree,  $D$  of the curve. The degree of the curve ( $D^\circ$ ) is the central angle subtended by an arc of length 30 m and is given by the relation,  $RD\pi/180 = 30$ . Therefore, the relation between the radius and degree of the circular curve is given by,  $R = 1720 / D$

When a vehicle traverses a horizontal curve, the centrifugal force acts horizontally outwards through the centre of gravity of the vehicle. The centrifugal force developed depends on the radius of the horizontal curve and the speed of the vehicle negotiating the curve. This centrifugal force is counteracted by the transverse frictional resistance developed between the tyres and the pavement which enables the vehicle to change the direction along the curve and to maintain the stability of the vehicle. Centrifugal force  $P$  is given by the equation:

$$P = \frac{Wv^2}{gR}$$

Where

$P$  = centrifugal force, kg

$W$  = weight of the vehicle, kg

$R$  = radius of the circular curve, m

$v$  = speed of vehicle, m/sec

$g$  = acceleration due to gravity = 9.8 m/sec

The ratio of the centrifugal force to the weight of the vehicle,  $P/W$  is known as the 'centrifugal ratio' or the 'impact factor'. Therefore, centrifugal ratio

$$\frac{P}{W} = \frac{v^2}{gR}$$

The centrifugal force acting on a vehicle negotiating a horizontal curve has the following two effects:

- 1) Tendency to overturn the vehicle outwards about the outer wheels
- 2) Tendency to skid the vehicle laterally, outwards

**Overtuning Effect**

The overturning moment due to centrifugal force,  $P = P \times h$

This is resisted by the restoring moment due to weight of the vehicle  $W$  and is equal to  $(Wb/2)$

The equilibrium condition for overturning will occur when  $P h = \frac{Wb}{2}$  or  $\frac{P}{W} = \frac{b}{2h}$   
 overturning will occur

And for safety  $\frac{b}{2h} > \frac{v^2}{gR}$

**Transverse Skidding Effect**

The centrifugal force developed has the tendency to push the vehicle outwards in the transverse direction.

The equilibrium condition for the transverse skid resistance developed is given by

$$\begin{aligned} F &= F_A + F_B \\ &= f (R_A + R_B) \\ &= f W \end{aligned}$$

Where  $f$  = coefficient of friction between the tyre and the pavement surface in the transverse direction

$R_A, R_B$  = Normal Reactions at the wheels A and B

$W$  = weight of the vehicle

When the centrifugal ratio  $\frac{P}{W} = f = \frac{v^2}{gR}$  skidding takes place

For safety  $f > \frac{v^2}{gR}$

Thus, to avoid both overturning and lateral skidding on a horizontal curve, the

$$\frac{P}{W} < \frac{b}{2h}$$

## SUPERELEVATION

In order to counteract the effect of centrifugal force and to reduce the tendency of the vehicle to overturn or skid, the outer edge of the pavement is raised with respect to the inner edge, thus providing a transverse slope throughout the length of the horizontal curve. This transverse inclination to the pavement surface is known as **SUPER ELEVATION or CANT or BANKING**.

The rate of super elevation, 'e' is expressed as the ratio of the height of outer edge with respect to the horizontal width.

$$e = \tan \theta = \sin \theta = \frac{NL}{ML} = \frac{E}{B}$$

E – Relative elevation of the outer edge

B – Width of the pavement

The general equation for design of super elevation is given by

$$e + f = \frac{v^2}{gR}$$

e = rate of super elevation =  $\tan \theta$

f = design value of lateral friction coefficient = 0.15

v = speed of the vehicle, m/sec

R = radius of the horizontal curve, m

g = acceleration due to gravity = 9.8 m/sec<sup>2</sup>

If the speed of the vehicle is given in kmph then the equation is

$$e + f = \frac{(0.278V)^2}{9.81R} = \frac{V^2}{127R}$$

The maximum value of super elevation is limited to 7% or 0.07 and the minimum value of lateral friction of coefficient f for highway is 0.15

In some situations, particularly at, some intersections it is not possible to provide super elevation and in such cases the friction counteracts the centrifugal force fully. The allowable speed of vehicle negotiating a turn should be restricted to the condition

$$V = \sqrt{127fR}$$

The super elevation depends upon

- 1) Radius of the curve R,
- 2) Speed of the vehicle V
- 3) The coefficient of lateral friction f

### Steps for Super Elevation Design

The steps for the design of super elevation in India from practical considerations (as per the IRC Guidelines) are given below:

- 1) The super elevation is calculated for 75% of design speed ( $0.75 v$  m/sec or  $0.75 V$  kmph), neglecting the friction

$$e = \frac{(0.75v)^2}{gR} \text{ or } \frac{(0.75V)^2}{127R}$$

$$e \approx \frac{V^2}{225R}$$

- 2) If the calculated value of 'e' is less than 7% or 0.07 the value so obtained provided. If the value of 'e' as per the above equation exceeds 0.07 then provide the maximum super elevation equal to 0.07 and proceed with steps 3 or 4
- 3) Check the coefficient of friction developed for the maximum value  $e = 0.07$  at the full value of design speed,  $v$  m/sec or  $V$  kmph

$$f = \left( \frac{v^2}{gR} - 0.07 \right) \text{ or } \left( \frac{V^2}{127R} - 0.07 \right)$$

If the value of  $f$  thus calculated is less than 0.15, the super elevation of 0.07 is safe for the design speed and this is accepted as the design super elevation. If not, either the radius of the horizontal curve has to be increased or the speed has to be restricted to the safe value which will be less than the design speed. The restricted speed or the allowable speed is calculated as given in step 4

- 4) The allowable speed or restricted speed ( $v_a$  m/sec or  $V_a$  kmph) at the  $cm^{1'}$  is calculated by considering the design coefficient of lateral friction and the maximum super elevation. The safe allowable speed

$$v_a = \sqrt{0.22 g R} = \sqrt{2.156R} \text{ m/sec}$$

or

$$V_a = \sqrt{27.94 R} \text{ kmph}$$

If the allowable speed, as calculated above is higher than the design speed, then the design is adequate and provide a super elevation of 'e' equal to 0.07. If the allowable speed is less than the design speed, the speed is limited to the allowable  $V_a$  kmph calculated above.

If the allowable speed  $V_a$  is less than the design speed  $V$ , appropriate warning signs and speed limit signs are to be installed.

### **Attainment of Super elevation in the field**

Introduction of super elevation on a horizontal curve in the field is an important feature in construction. The road cross section at the straight portion is cambered with the crown at the center of the pavement and sloping down towards both the edges. But the cross section on the portion of circular curve of the road is super elevated with a uniform tilt sloping down from the outer edge of the pavement up to inner edge.

Thus, the crowned camber sections at the straight before the start of the transition curve should be changed to a single cross slope equal to the desired superelevation at the beginning of the circular curve. This change may be conveniently attained at a gradual and uniform rate through the length of horizontal transition curve. The full superelevation is attained by the end of transition curve or at the beginning of the circular curve.

The attainment of superelevation may be split up into two parts:

- (a) Elimination of crown of the cambered section
- (b) Rotation of pavement to attain full superelevation

### RADIUS OF HORIZONTAL CURVE

Horizontal curves of highways are generally designed for the specified ruling design speed of the highway. However, if this is not possible due to site restrictions, the horizontal curves may be designed considering the specified minimum design speed of the highway.

For a particular speed of vehicle, the centrifugal force is dependent on the radius of the horizontal curve. To keep the centrifugal ratio  $P/W$  or  $v^2/gR$  within a low limit, the radius of the horizontal curve should be kept correspondingly high. The centrifugal force,  $P$  developed due to a vehicle negotiating a horizontal curve of radius,  $R$  at a speed,  $v$  m/sec or  $V$  kmph is counteracted by the superelevation,  $e$  and lateral friction coefficient,  $f$ .

$$R_{ruling} = \frac{v^2}{(e + f)g}$$

Also

$$R_{ruling} = \frac{V^2}{127(e + f)}$$

The minimum design speed is  $V'$  Kmph, the absolute minimum radius of horizontal curve

$$R_{min} = \frac{V'^2}{127(e + f)}$$

$v$  and  $V$  – ruling speeds in m/sec and Kmph

$V'$  – minimum design speed in kmph

$e$  - rate of superelevation, (0.07)

$f$  – coefficient of friction 0.15

$g$  - acceleration due to gravity 9.8 m/sec<sup>2</sup>



**WIDENING OF PAVEMENT ON HORIZONTAL CURVES****Objectives**

- 1) An automobile such as car, bus or truck has a rigid wheel base and only the front wheels can be turned. When the vehicle takes a turn to negotiate a horizontal curve, the rear wheels do not follow the same path as that of the front wheels. This phenomenon is called 'off tracking'. Normally at low speeds and up to the design speed when no lateral slipping of rear wheels take place, the rear wheels follow the inner path on the curve as compared with those of the corresponding front wheels. This means that if inner front wheel takes a path on the inner edge of a pavement at a horizontal curve, inner rear wheel will be off the pavement on the inner shoulder.

The off-tracking depends on

- a) The length of the wheel base of the vehicle
  - b) The turning angle or the radius of the horizontal curve negotiated.
- 
- 2) At speeds, higher than the design speeds when the superelevation and lateral friction developed are not fully able to counteract the outwards thrust due to the centrifugal force, some transverse skidding may occur and the rear wheels may take paths on the outside of those traced by the front wheels on the horizontal curves. However, this occurs only at excessively high speeds
  - 3) The path traced by the wheels of a trailer in the case of trailer units, is also likely to be on either side of the central path of the towing vehicle, depending on the speed, rigidity of the universal joints and pavement roughness
  - 4) In order to take curved path with larger radius and to have greater visibility at curve, the drivers have tendency not to follow the central path of the lane, but to use the outer side at the beginning of a curve.

- 5) While two vehicles cross or overtake at horizontal curve there is a psychological tendency to maintain a greater clearance between the vehicles, than on straights for increase safety

Thus, the required extra widening of the pavement at the horizontal curves,  $W_e$  depends on

- The Length of wheel based of the vehicle  $l$ ,
- Radius of the curve negotiated  $R$
- The psychological factor which is a function of the speed of the vehicle and the radius of the curve.

It has been a practice therefore to provide extra width of pavement on horizontal curves when the radius is less than about **300 m**.

### Analysis of Extra Widening on Horizontal Curves

The extra widening of pavement on horizontal curves is divided into two parts.

#### Mechanical Widening

The widening required to account for the off-tracking due to rigidity of wheel base is called as 'Mechanical Widening' ( $W_m$ ) and is given by

$$W_m = \frac{nl^2}{2R}$$

#### Psychological Widening

Widening of pavements has to be done for some psychological reasons also. There is a tendency for the drivers to drive close to the edges of the pavement on curves. Some extra space is to be provided for more clearance for the crossing and overtaking operations on curves. IRC proposed an empirical relation for the psychological widening at horizontal curves.

$$W_{ps} = \frac{V}{9.5\sqrt{R}}$$

Hence Total Widening  $W_e$  is given by  $W_e = W_m + W_{ps}$

$$W_e = \frac{nl^2}{2R} + \frac{V}{9.5\sqrt{R}}$$

$R$  – Radius of the curve

$n$  – No of lanes

$l$  – length of wheel base of longest vehicle, m

Radius of Curve, m	Up to 20	20 to 40	41 to 60	61 to 100	101 to 300	Above 300
Extra width on two-lane pavement, m	1.5	1.5	1.2	0.9	0.6	Nil
Extra width on single lane pavement, m	0.9	0.6	0.6	Nil	Nil	Nil

Note: For multi lane roads, the pavement widening is calculated by adding half extra width of two lane roads to each lane of the multi lane road.

### Horizontal Transition Curves

Transition curve is provided to change the horizontal alignment from straight to circular curve gradually and has a radius which decreases from infinity at the straight end (tangent point) to the desired radius of the circular curve at the other end (curve point)

Thus, the functions of transition curve in the horizontal alignment are given below:

- To introduce gradually the centrifugal force between the tangent point and the beginning of the circular curve, avoiding sudden jerk on the vehicle. This increases the comfort of passengers.
- To enable the driver, turn the steering gradually for his own comfort and safety
- To enable gradual introduction of the designed super elevation and extra widening of pavement at the start of the circular curve.
- To improve the aesthetic appearance of the road

### Type of transition curve

Different types of transition curves are

- a) Spiral or Clothoid
- b) Cubic Parabola
- c) Lemniscates

IRC recommends spiral as the transition curve because:

- 1) It full fills the requirement of an ideal transition, as the rate of change of centrifugal acceleration is uniform throughout the length.
- 2) The geometric property of spiral is such that the calculation and setting out the curve in the field is simple and easy.

### Length of transition curve

The length of the transition curve should be determined as the maximum of the following three criteria

- 1) Rate of Change of Centrifugal Acceleration
- 2) Rate of Change of Super Elevation
- 3) An Empirical Formula Given by IRC

### Rate of Change of Centrifugal Acceleration

At the tangent point, radius is infinity and hence centrifugal acceleration ( $v^2/R$ ) is zero, as the radius is infinity. At the end of the transition, the radius R has minimum value  $R_m$ . Hence the rate of change of centrifugal acceleration is distributed over a length  $L_s$

Let the length of transition curve be  $L_s$  m. If 't' is the time taken in seconds to traverse this transition length at uniform design speed of  $v$  m/sec,  $t = L_s/v$ . The maximum centrifugal acceleration of  $v^2/R$  is introduced in time  $t$  through the transition length  $L_s$  and hence the rate of centrifugal acceleration  $C$  is given by

$$C = \frac{v^2}{Rt} = \frac{\frac{v^2}{RL_s}}{v} = \frac{v^3}{L_s R}$$

The IRC has recommended the following equation

$$C = \frac{80}{(75 + V)}$$

The minimum and maximum value of  $C$  are limited to 0.5 and 0.8

The length of the transition curve  $L_s$  is given by

$$L_s = \frac{v^3}{CR}$$

If the design speed is given in kmph

$$L_s = \frac{V^3}{46.5 CR}$$

C - rate of change of centrifugal acceleration, m/sec<sup>3</sup>

L<sub>s</sub> – length of transition curve

R – radius of the circular curve, m

### Rate of introduction of super-elevation

Raise (E) of the outer edge with respect to inner edge is given by

$$E = eB = e(W + W_e)$$

If it is assumed that the pavement is rotated about the centre line after neutralizing the camber, then the max amount by which the outer edge is to be raised at the circular curve with respect to the centre = E/2. Hence the rate of change of this raise from 0 to E is achieved gradually with a gradient of 1 in N over the length of the transition curve (typical range of N is 60-150).

Therefore, the length of the transition curve L<sub>s</sub> is given by

$$L_s = \frac{EN}{2} = \frac{eN}{2} (W + W_e)$$

However, if the pavement is rotated about the inner edge, the length of transition curve is given by

$$L_s = EN = eN (W + W_e)$$

### By Empirical Formula

According to IRC standards the length of horizontal transition curve L<sub>s</sub> should not be less than the value given by the following formulas for two terrain classification

a) For plain and rolling terrain

$$L_s = \frac{2.7 V^2}{2}$$

b) For mountainous and steep terrain

$$L_s = \frac{V^2}{2}$$

### Setting out Transition Curve

Transition curves are introduced between the tangent points of the straight stretches and the end of the circular curve on both sides. If the length of transition curve is  $L_s$  and the radius of the circular curve is  $R$ , the shift  $S$  of the transition curve is given by the formula

$$S = \frac{L_s^2}{24 R}$$

### Setback Distance on Horizontal Curves

Setback distance  $m$  or the clearance distance is the distance required from the centreline of a horizontal curve to an obstruction on the inner side of the curve to provide adequate sight distance at a horizontal curve. The setback distance depends on:

- Required Sight Distance,  $S$
- Radius of Horizontal Curve,  $R$
- Length of the curve,  $L_c$  which may be greater or lesser than  $S$

#### a) When $L_c > S$

When the length of curve  $L_c$  is greater than the sight distance  $S$ , let the angle subtended by the arc length  $S$  at the curve be  $\alpha$ . On narrow roads such as single lane roads, the sight distance is measured along the centre line of the road and the angle subtended at the centre,  $\alpha$  is equal to  $S/R$  radians. Therefore, half central angle is given by

$$\frac{\alpha}{2} = \frac{S}{2 R} \text{ radians} = \frac{180 S}{2 \pi R} \text{ degrees}$$

The setback distance  $m$ , required from the centre line on narrow road is given by

$$m = R - R \cos \frac{\alpha}{2}$$

In case of wide roads with 2 or more lanes, if  $d$  is the distance between the centre line of the road and the centre line of the inside lane in meters, the sight distance is measured along the middle of the inner side lanes and the setback distance  $m'$  is given by

$$m' = R - (R - d) \cos \frac{\alpha'}{2}$$

Where

$$\frac{\alpha'}{2} = \frac{180 S}{2 \pi (R - d)} \text{ degrees}$$

**b) When  $L_c < S$** 

If the length of the curve  $L_c$  is less than the required sight distance  $S$ , then the angle  $\alpha$  subtended at the center is determined with reference to the length of circular curve  $L_c$  and the setback distance  $m'$  is worked out in 2 parts

$$\frac{\alpha'}{2} = \frac{180 L_c}{2 \pi(R - d)} \text{ degrees}$$

The setback distance is given by

$$m' = R - (R - d) \cos \frac{\alpha'}{2} + \frac{(S - L_c)}{2} \sin \frac{\alpha'}{2}$$

**Curve Resistance**

When the vehicle negotiates a horizontal curve, the direction of rotation of the front and the rear wheels are different. The front wheels are turned to move the vehicle along the curve, whereas the rear wheels seldom turn. The rear wheels exert a tractive force  $T$  in the PQ direction. The tractive force available on the front wheels is  $T \cos \theta$  in the PS direction. This is less than the actual tractive force,  $T$  applied. Hence, the loss of tractive force for a vehicle to negotiate a horizontal curve is:

$$\mathbf{CR = T - T \cos \alpha = T (1 - \cos \alpha)}$$

## DESIGN OF VERTICAL ALIGNMENT

### INTRODUCTION

The natural ground or the topography may be level at some places, but may have slopes of varying magnitudes at other locations. While aligning a highway it is the common practice to follow the general topography or profile of the land, keeping in view the drainage and other requirements on each stretch. This is particularly with a view to minimise deep cuttings and very high embankments. Hence the vertical profile of a road would have level stretches as well as slopes or grades.

In order to have smooth vehicle movements on the roads, the changes in the gradient should be smoothed out by the vertical curves. The vertical alignment is the elevation or profile of the centre line of the road. The vertical alignment consists of grades and vertical curves.

The vertical alignment of a highway influences

- 1) Vehicle Speed
- 2) Acceleration and Deceleration
- 3) Stopping Distance
- 4) Sight Distance
- 5) Comfort While Travelling at High Speeds
- 6) Vehicle Operation Cost.

### Gradient

Gradient is the rate of rise or fall along the length of the road with respect to the horizontal. It is expressed as a ratio of 1 in x (1 vertical unit to x horizontal units). The gradient is also expressed as percentages such as n%, the slope being n vertical units to 100 horizontal units

### Types of gradient

- a) Ruling Gradient
- b) Limiting Gradient
- c) Exceptional Gradient
- d) Minimum Gradient



**Ruling gradient**

The ruling gradient or the design gradient is the maximum gradient with which the designer attempts to design the vertical profile of the road. This depends on the terrain, length of the grade, speed, pulling power of the vehicle and the presence of the horizontal curve. In plain terrain, it may be possible to provide at gradients, but in hilly terrain it is not economical and sometimes not possible also.

The IRC has recommended ruling gradient values of

- a) 1 in 30 on plain and rolling terrain
- b) 1 in 20 on mountainous terrain
- c) 1 in 16.7 on steep terrain.

**Limiting gradient**

Where topography of a place compels adopting steeper gradient than the ruling gradient, 'limiting gradient' is used in view of enormous increase in cost in constructing roads with gentler gradients. However, the length of continuous grade line steeper than ruling gradient should be limited. On rolling terrain and on hill roads, it may be frequently necessary to exceed ruling gradient and adopt limiting gradient, but care should be taken to separate such stretches of steep gradients by providing either a level road or a road with easier grade.

**Exceptional gradient**

In some extra ordinary situations, it may be unavoidable to provide still steeper gradients than limiting gradient at least for short stretches and in such cases the steeper gradient up to 'exceptional gradient' may be provided. However, the exceptional gradient should be strictly limited only for short stretches not exceeding about 100 m at a stretch.

**Minimum gradient**

This is important only at locations where surface drainage is important. Camber will take care of the lateral drainage. But the longitudinal drainage along the side drains requires some slope for smooth flow of water.

The road with zero gradient passing through level land and open side drains are provided with a gradient of 1 in 400. A minimum of 1 in 500 may be sufficient to drain water in concrete drains or gutter, on inferior surface of drains 1 in 200 or 0.5%, on kutcha open drains steeper slope up to 1 in 100 or 1 % may be provided

**Gradient for roads in different terrains**

Type of Terrain	Ruling Gradient	Limiting Gradient	Exceptional Gradient
Plain or Rolling	3.3 %, 1 in 30	5 %, 1 in 20	6.7 %, 1 in 15
Mountainous terrain and steep terrain having elevation more than 3000 m above the mean sea level	5 %, 1 in 20	6 %, 1 in 16.7	7 %, 1 in 14.3
Steep terrain up to 3000 m height above mean sea level	6 %, 1 in 16.7	7 %, 1 in 14.3	8 %, 1 in 12.5

**Grade Compensation on Horizontal Curve**

When sharp horizontal curve is to be introduced on a road which has already the maximum permissible gradient, then the gradient should be decreased to compensate for the loss of tractive effort due to curve. This reduction in gradient at the horizontal curve is called Grade compensation or compensation in gradient at the horizontal curve, which is intended to off-set the extra tractive effort involved at the curve. This is calculated from the below equation

$$\text{Grade Compensation \%} = \frac{30+R}{R}$$

The max value of grade compensation is limited to  $75/R$ , where R is the radius of the circular curve in m

As per IRC the grade compensation is not necessary for gradients flatter than 4.0 %, and therefore when applying grade compensation correction, the gradients need not be eased beyond 4 %. **The compensated gradient = Ruling Gradient – Grade Compensation**

## Vertical Curves

Due to changes in grade in the vertical alignment of highway, it is necessary to introduce vertical curve at the intersections of different grades to smoothen out the vertical profile and thus ease off the changes in gradients for the fast moving vehicles.

The vertical curves used in highway may be classified into two categories:

- Summit curves or crest curves with convexity upwards
- Valley curves or sag curves with concavity upwards

### Summit curves

Summit curves with convexity upwards are formed in any one of the cases as given below

- When a positive gradient meets another positive gradient
- When positive gradient meets a at gradient
- When an ascending gradient meets a descending gradient.
- When a descending gradient meets another descending gradient

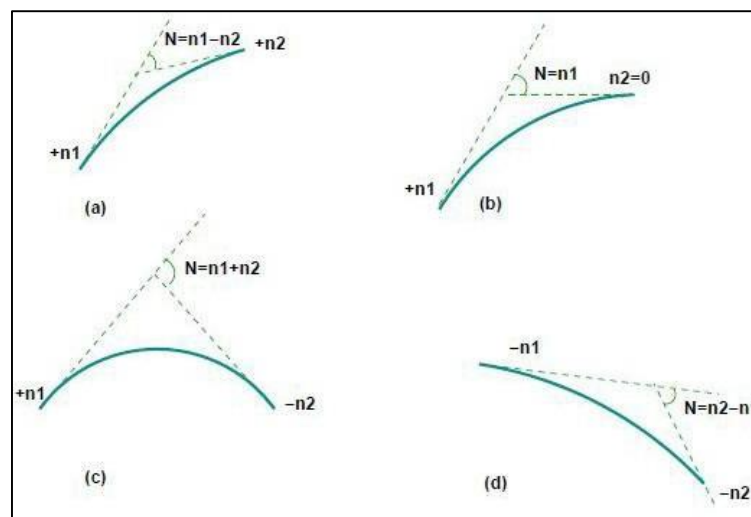

The deviation angle,  $N$  between the two intersecting gradients is equal to the algebraic difference between them. Among all the cases, the deviation angle will be maximum when an ascending gradient,  $(+n_1)$  meets with a descending gradient,  $(-n_2)$ .

Therefore, deviation angle,  $N = n_1 - (-n_2) = (n_1 + n_2)$

When a fast moving vehicle travels along a summit curve, the centrifugal force will act upwards, against gravity and hence a part of the self-weight of the vehicle is relieved resulting in reduction in pressure on the tyres and on the suspension springs of the vehicle suspensions. So there is no problem of discomfort to passengers on summit curves, particularly because the deviation angles on roads are quite small. Also if the summit curve is designed to have adequate

sight distance, the length of the summit curve would be long enough to ease the shock due to change in gradients.

### **Type of Summit Curve**

Many curve forms can be used with satisfactory results; the common practice has been to use parabolic curves in summit curves. This is primarily because of the ease with it can be laid out as well as allowing a comfortable transition from one gradient to another.

### **LENGTH OF THE SUMMIT CURVE**

The important design aspect of the summit curve is the determination of the length of the curve which is parabolic. As noted earlier, the length of the curve is guided by the sight distance consideration.

#### **Length of the summit curve for SSD**

##### **a) When $L > SSD$**

The equation for length  $L$  of the parabolic curve is given by

$$L = \frac{NS^2}{(\sqrt{2H} + \sqrt{2h})^2}$$

Here

$L$  – length of summit curve, m

$S$  – SSD, m

$N$  – Deviation angle, equal to algebraic difference in grades, radians, or tangent of deviation angle

$H$  - Height of eye level of driver above road surface, m = 1.2m

$h$  – Height of subject above the pavement surface, m = 0.15m

As per IRC

$$L = \frac{NS^2}{4.4}$$

**b) When  $L < SSD$** 

The equation for length  $L$  of the parabolic curve is given by

$$L = 2S - \frac{(\sqrt{2H} + \sqrt{2h})^2}{N}$$

As per IRC

$$L = 2S - \frac{4.4}{N}$$

The minimum radius of parabolic summit curve is given by  $R/N$

**Length of the summit curve for OSD or ISD****a) When  $L > OSD$  or  $ISD$** 

The equation for length  $L$  of the parabolic curve is given by

$$L = \frac{NS^2}{8H}$$

As per IRC

$$L = \frac{NS^2}{9.6}$$

$S$  – OSD or ISD, m

**b) When  $L < OSD$  or  $ISD$** 

The equation for length  $L$  of the parabolic curve is given by

$$L = 2S - \frac{8H}{N}$$

As per IRC

$$L = 2S - \frac{9.6}{N}$$

## Valley curve

Valley curve or sag curves are vertical curves with convexity downwards. The deviation angle,  $N$  between the two intersecting gradients is equal to the algebraic difference between them. Among all the cases, the deviation angle will be maximum when a descending gradient,  $(-n_1)$  meets with an ascending gradient,  $(+n_2)$ .

Therefore, deviation angle,  $N = -n_1 - (+n_2) = -(n_1 + n_2)$

They are formed when two gradients meet as illustrated in figure below in any of the following four ways:

- 1) When a descending gradient meets another descending gradient
- 2) When a descending gradient meets a at gradient
- 3) When a descending gradient meets an ascending gradient
- 4) When an ascending gradient meets another ascending gradient

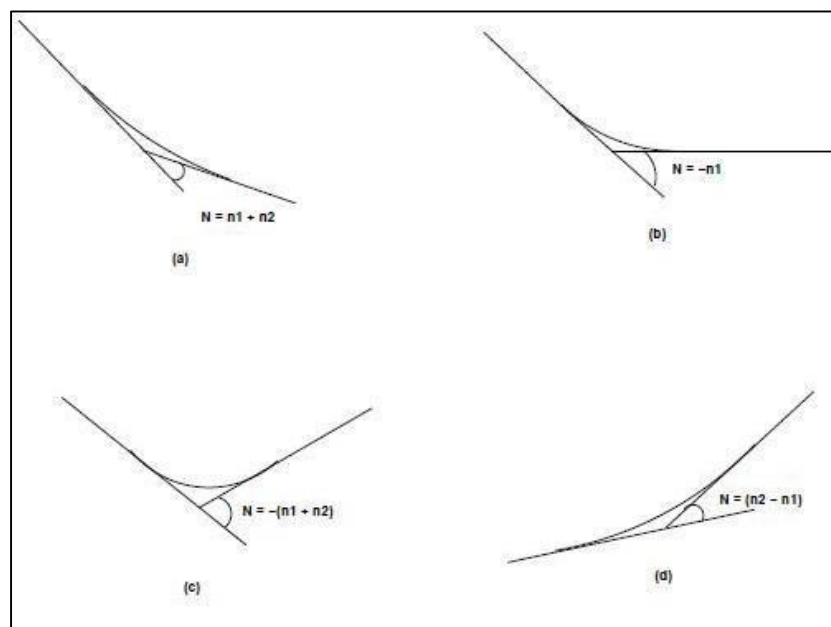

## Length of the valley curve

The length of the valley transition curve is designed to fulfil two criteria

- a) Allowable rate change of centrifugal acceleration
- b) The required HSD for night driving

**Length of transition curve for Comfort condition**

The equation for length L of the parabolic curve is given by

$$L = 2 \left[ \frac{Nv^3}{C} \right]^{\frac{1}{2}} = 0.38(NV^3)^{\frac{1}{2}}$$

Where

L – Total length of valley curve = 2Ls

N – Deviation angle, equal to algebraic difference in grades, radians, or tangent of deviation angle

C – the allowable rate of change of centrifugal acceleration, the value of C may be taken as 0.6m/sec<sup>3</sup>

v – Design speed in m/s

V – design speed in kmph

The minimum radius of cubic parabolic valley curve is given by  $R = \frac{Ls}{N} = \frac{L}{2N}$

**Length of the summit curve for OSD or ISD****a) When L > OSD or ISD**

If the valley curve is assumed to be parabolic shape, with equation  $y = a x^2$ , where  $a = N/2L$

The equation for length L of the parabolic curve is given by

$$h_1 + S \tan \alpha = a S^2 = \frac{NS^2}{2L}$$

Where

h<sub>1</sub> – the average height of head light = 0.75m

α - 1°, the beam angle

$$L = \frac{NS^2}{(1.5 + 0.035S)}$$

L – Total length of valley curve, m

S – OSD or ISD, m

N - Deviation angle = (n<sub>1</sub> + n<sub>2</sub>), with slopes – n<sub>1</sub> and + n<sub>2</sub>

**b) When L < OSD or ISD**

The equation for length  $L$  of the parabolic curve is given by

$$h_1 + S \tan \alpha = \left( S - \frac{L}{2} \right) N$$

Where

$h_1$  – the average height of head light = 0.75m

$\alpha$  - 1°, the beam angle

$$L = 2S - \frac{(1.5 + 0.035S)}{N}$$